

Planes, training and optimobiles: adding value to optimisation in the real world

Sandy Brownlee

- Scene setting
- Tasters
- Aircraft taxiing
- Buildings

Value-added
optimisation

Optimisation

- Change something (the variables) to influence the things we care about (the objectives). Depending on the variables, there can be millions, billions or infinite possible solutions to explore.

**Designs /
options**



**Quality /
goals**

WHY?

HOW?

NEXT TIME?

TASTERS

Can we fine-tune software to run faster, produce better results and extend battery life?



Yes, but (usually) not all at the same time!

Can we take an existing piece of software and make it run faster?



Opium software:

All KLM flight schedules pass through Opium

Each covers 3 months, ~17k flights

YES!

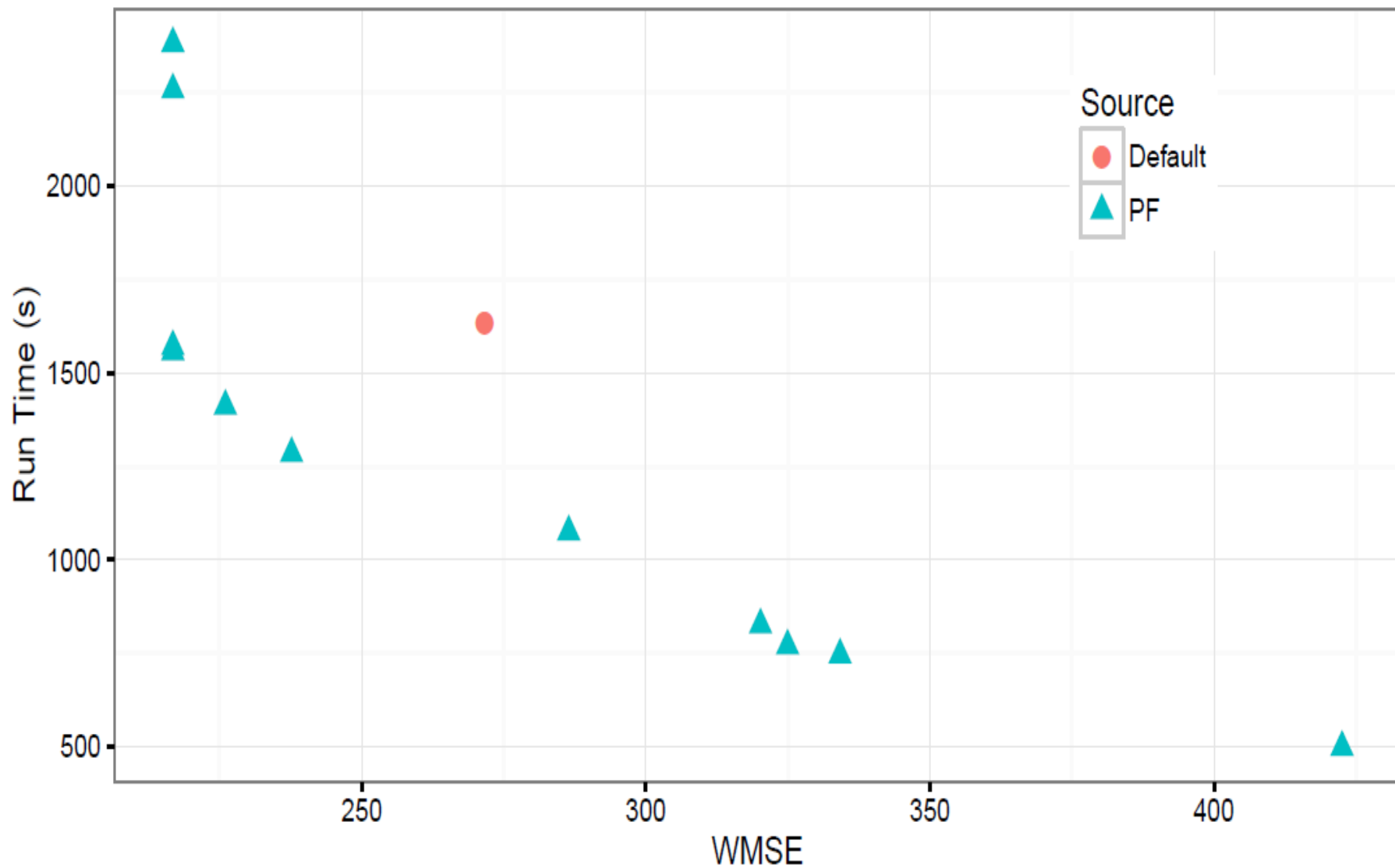

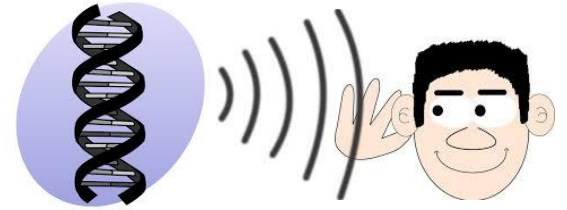

Can we use the feedback of lots of people to make a collective decision:

"crowdsourcing the sounds of places"

Maybe!

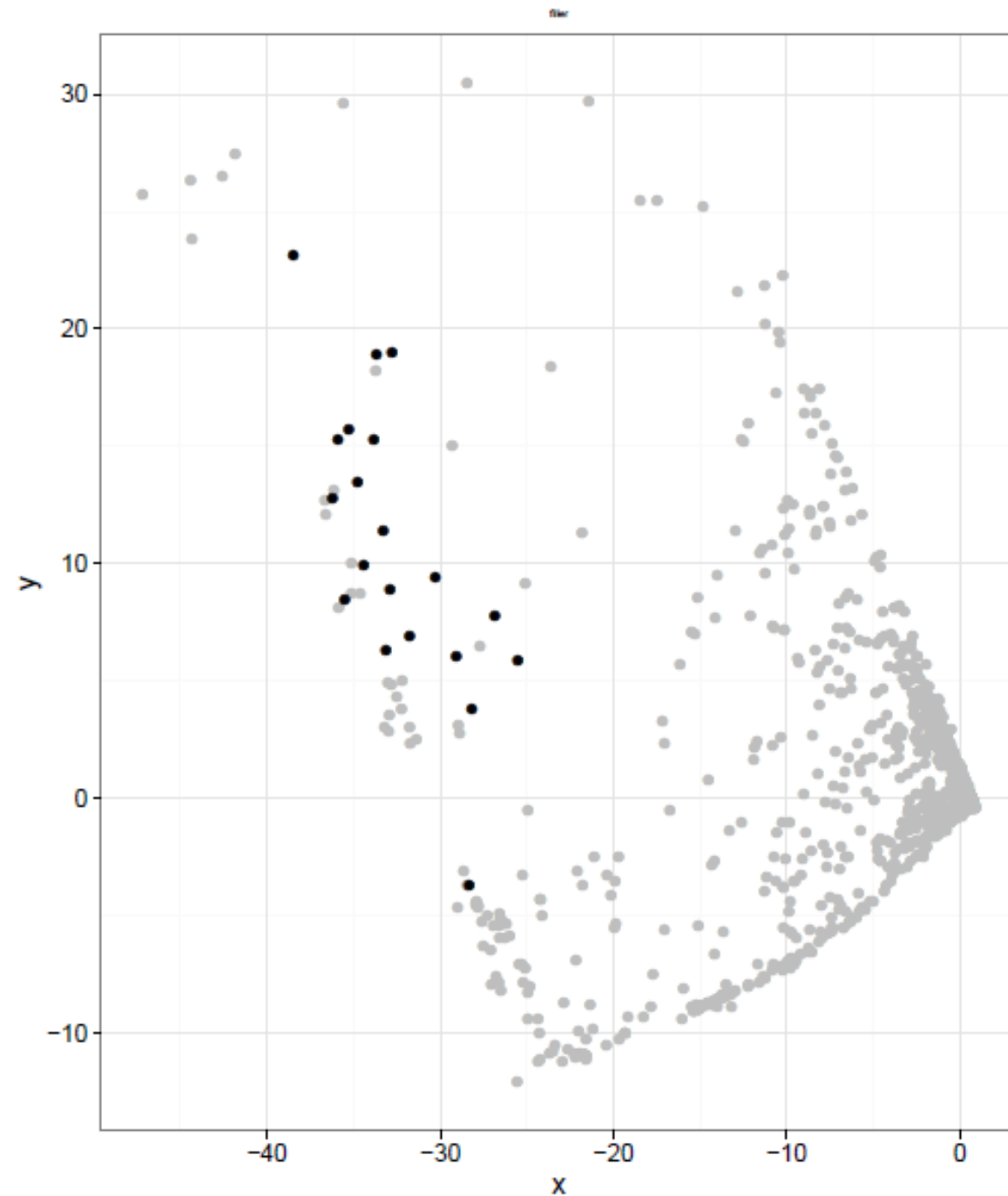

Can we automatically generate new algorithms that solve different problems to those we already have?

Probably!

Understanding
the *structure* of
combinatorial
problems...

TABLE II. RESULTS FOR ALL 75 2-BIT RANK EQUIVALENT CLASSES. COLUMN HEADINGS ARE DESCRIBED IN THE TEXT.

Cat	C	Ranks	Structure	Tournament		Top			Bottom			T+B			LDA
				Best	Worst	0.25	0.33	0.5	0.25	0.33	0.5	0.25	0.33	0.5	
1	0	0000	<input type="checkbox"/>	00	00	00	00	00	00	00	00	00	00	00	N
2	1	0001	<input type="checkbox"/>	00	00	00	00	00	00	00	00	00	00	00	Y
	2	0010	<input type="checkbox"/>	00	00	00	00	00	00	00	00	00	00	00	Y
	3	0100	<input type="checkbox"/>	00	00	00	00	00	00	00	00	00	00	00	Y
	4	1000	<input type="checkbox"/>	00	00	00	00	00	00	00	00	00	00	00	Y
3	5	1110	<input type="checkbox"/>	00	00	00	00	00	00	00	00	00	00	00	Y
	6	1101	<input type="checkbox"/>	00	00	00	00	00	00	00	00	00	00	00	Y
	7	1011	<input type="checkbox"/>	00	00	00	00	00	00	00	00	00	00	00	Y
	8	0111	<input type="checkbox"/>	00	00	00	00	00	00	00	00	00	00	00	Y
4	9	0011	<input type="checkbox"/>	00	00	00	00	00	00	00	00	00	00	00	N
	10	0101	<input type="checkbox"/>	00	00	00	00	00	00	00	00	00	00	00	N
	11	1001	<input type="checkbox"/>	00	00	00	00	00	00	00	00	00	00	00	Y
	12	0110	<input type="checkbox"/>	00	00	00	00	00	00	00	00	00	00	00	Y
	13	1010	<input type="checkbox"/>	00	00	00	00	00	00	00	00	00	00	00	N
	14	1100	<input type="checkbox"/>	00	00	00	00	00	00	00	00	00	00	00	N
	15	0010	<input type="checkbox"/>	00	00	00	00	00	00	00	00	00	00	00	N
5	16	0021	<input type="checkbox"/>	00	00	00	00	00	00	00	00	00	00	00	Y
	17	0201	<input type="checkbox"/>	00	00	00	00	00	00	00	00	00	00	00	Y
	18	2001	<input type="checkbox"/>	00	00	00	00	00	00	00	00	00	00	00	Y
	19	0102	<input type="checkbox"/>	00	00	00	00	00	00	00	00	00	00	00	Y
	20	0120	<input type="checkbox"/>	00	00	00	00	00	00	00	00	00	00	00	Y
	21	0210	<input type="checkbox"/>	00	00	00	00	00	00	00	00	00	00	00	Y
	22	2010	<input type="checkbox"/>	00	00	00	00	00	00	00	00	00	00	00	Y
	23	1002	<input type="checkbox"/>	00	00	00	00	00	00	00	00	00	00	00	Y
	24	1020	<input type="checkbox"/>	00	00	00	00	00	00	00	00	00	00	00	Y
	25	1200	<input type="checkbox"/>	00	00	00	00	00	00	00	00	00	00	00	Y
	26	2100	<input type="checkbox"/>	00	00	00	00	00	00	00	00	00	00	00	Y
6	27	1102	<input type="checkbox"/>	00	00	00	00	00	00	00	00	00	00	00	Y
	28	1120	<input type="checkbox"/>	00	00	00	00	00	00	00	00	00	00	00	Y
	29	1210	<input type="checkbox"/>	00	00	00	00	00	00	00	00	00	00	00	Y
	30	2110	<input type="checkbox"/>	00	00	00	00	00	00	00	00	00	00	00	N
	31	1012	<input type="checkbox"/>	00	00	00	00	00	00	00	00	00	00	00	Y
	32	1021	<input type="checkbox"/>	00	00	00	00	00	00	00	00	00	00	00	N
	33	1201	<input type="checkbox"/>	00	00	00	00	00	00	00	00	00	00	00	N
	34	2101	<input type="checkbox"/>	00	00	00	00	00	00	00	00	00	00	00	Y
	35	0112	<input type="checkbox"/>	00	00	00	00	00	00	00	00	00	00	00	N
	36	0121	<input type="checkbox"/>	00	00	00	00	00	00	00	00	00	00	00	Y
	37	0211	<input type="checkbox"/>	00	00	00	00	00	00	00	00	00	00	00	Y
	38	2011	<input type="checkbox"/>	00	00	00	00	00	00	00	00	00	00	00	Y
7	39	2201	<input type="checkbox"/>	00	00	00	00	00	00	00	00	00	00	00	Y
	40	2210	<input type="checkbox"/>	00	00	00	00	00	00	00	00	00	00	00	Y
	41	2120	<input type="checkbox"/>	00	00	00	00	00	00	00	00	00	00	00	Y
	42	1220	<input type="checkbox"/>	00	00	00	00	00	00	00	00	00	00	00	Y
	43	2021	<input type="checkbox"/>	00	00	00	00	00	00	00	00	00	00	00	Y
	44	2012	<input type="checkbox"/>	00	00	00	00	00	00	00	00	00	00	00	Y
	45	2102	<input type="checkbox"/>	00	00	00	00	00	00	00	00	00	00	00	Y
	46	1202	<input type="checkbox"/>	00	00	00	00	00	00	00	00	00	00	00	Y
	47	0221	<input type="checkbox"/>	00	00	00	00	00	00	00	00	00	00	00	Y
	48	0212	<input type="checkbox"/>	00	00	00	00	00	00	00	00	00	00	00	Y
	49	0122	<input type="checkbox"/>	00	00	00	00	00	00	00	00	00	00	00	Y
	50	1022	<input type="checkbox"/>	00	00	00	00	00	00	00	00	00	00	00	Y
8	51	0123	<input type="checkbox"/>	00	00	00	00	00	00	00	00	00	00	00	N
	52	0132	<input type="checkbox"/>	00	00	00	00	00	00	00	00	00	00	00	Y
	53	0213	<input type="checkbox"/>	00	00	00	00	00	00	00	00	00	00	00	N
	54	0231	<input type="checkbox"/>	00	00	00	00	00	00	00	00	00	00	00	Y
	55	0321	<input type="checkbox"/>	00	00	00	00	00	00	00	00	00	00	00	Y
	56	0312	<input type="checkbox"/>	00	00	00	00	00	00	00	00	00	00	00	Y
	57	1023	<input type="checkbox"/>	00	00	00	00	00	00	00	00	00	00	00	Y
	58	1032	<input type="checkbox"/>	00	00	00	00	00	00	00	00	00	00	00	N
	59	1203	<input type="checkbox"/>	00	00	00	00	00	00	00	00	00	00	00	Y
	60	1230	<input type="checkbox"/>	00	00	00	00	00	00	00	00	00	00	00	Y
	61	1320	<input type="checkbox"/>	00	00	00	00	00	00	00	00	00	00	00	Y
	62	1302	<input type="checkbox"/>	00	00	00	00	00	00	00	00	00	00	00	N
	63	2103	<input type="checkbox"/>	00	00	00	00	00	00	00	00	00	00	00	Y
	64	2130	<input type="checkbox"/>	00	00	00	00	00	00	00	00	00	00	00	Y
	65	2013	<input type="checkbox"/>	00	00	00	00	00	00	00	00	00	00	00	Y
	66	2031	<input type="checkbox"/>	00	00	00	00	00	00	00	00	00	00	00	N
	67	2301	<input type="checkbox"/>	00	00	00	00	00	00	00	00	00	00	00	N
	68	2310	<input type="checkbox"/>	00	00	00	00	00	00	00	00	00	00	00	Y
	69	3120	<input type="checkbox"/>	00	00	00	00	00	00	00	00	00	00	00	N
	70	3102	<input type="checkbox"/>	00	00	00	00	00	00	00	00	00	00	00	Y
	71	3210	<input type="checkbox"/>	00	00	00	00	00	00	00	00	00	00	00	N
	72	3201	<input type="checkbox"/>	00	00	00	00	00	00	00	00	00	00	00	Y
	73	3021	<input type="checkbox"/>	00	00	00	00	00	00	00	00	00	00	00	Y
	74	3012	<input type="checkbox"/>	00	00	00	00	00	00	00	00	00	00	00	Y

Huge symmetries
across the space
of problems

Research Programme

Being Together - exploring large data sets: all about the personal, questions of power, influence, privacy and security

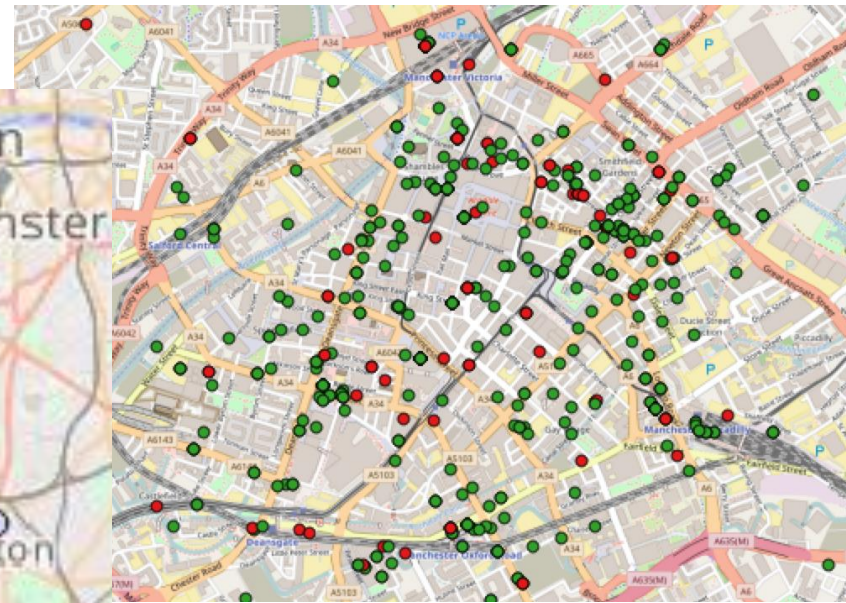
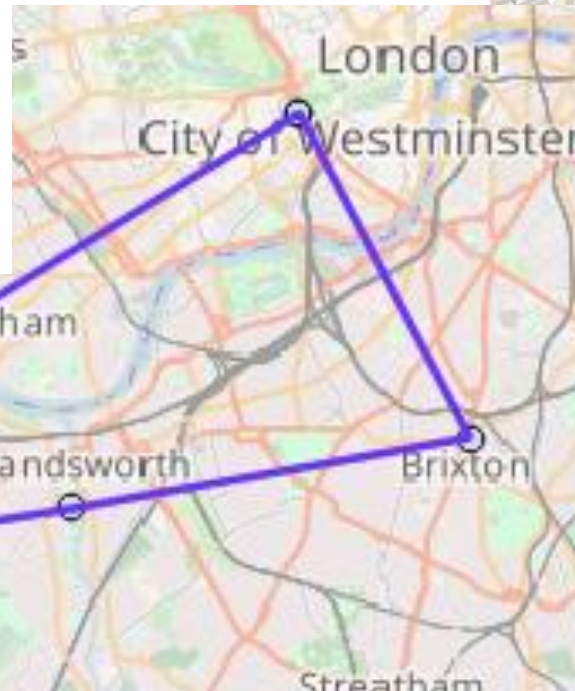
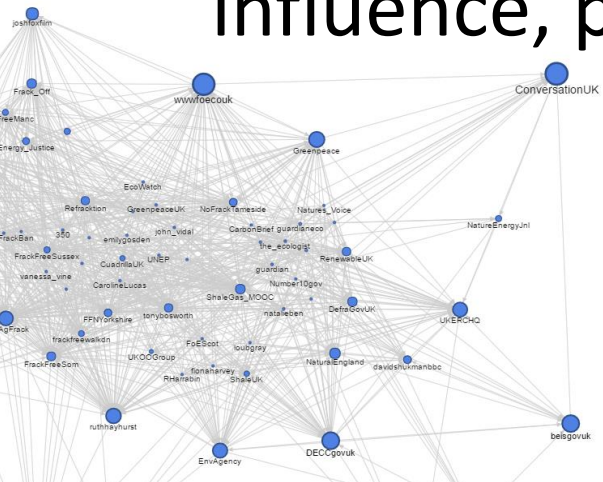



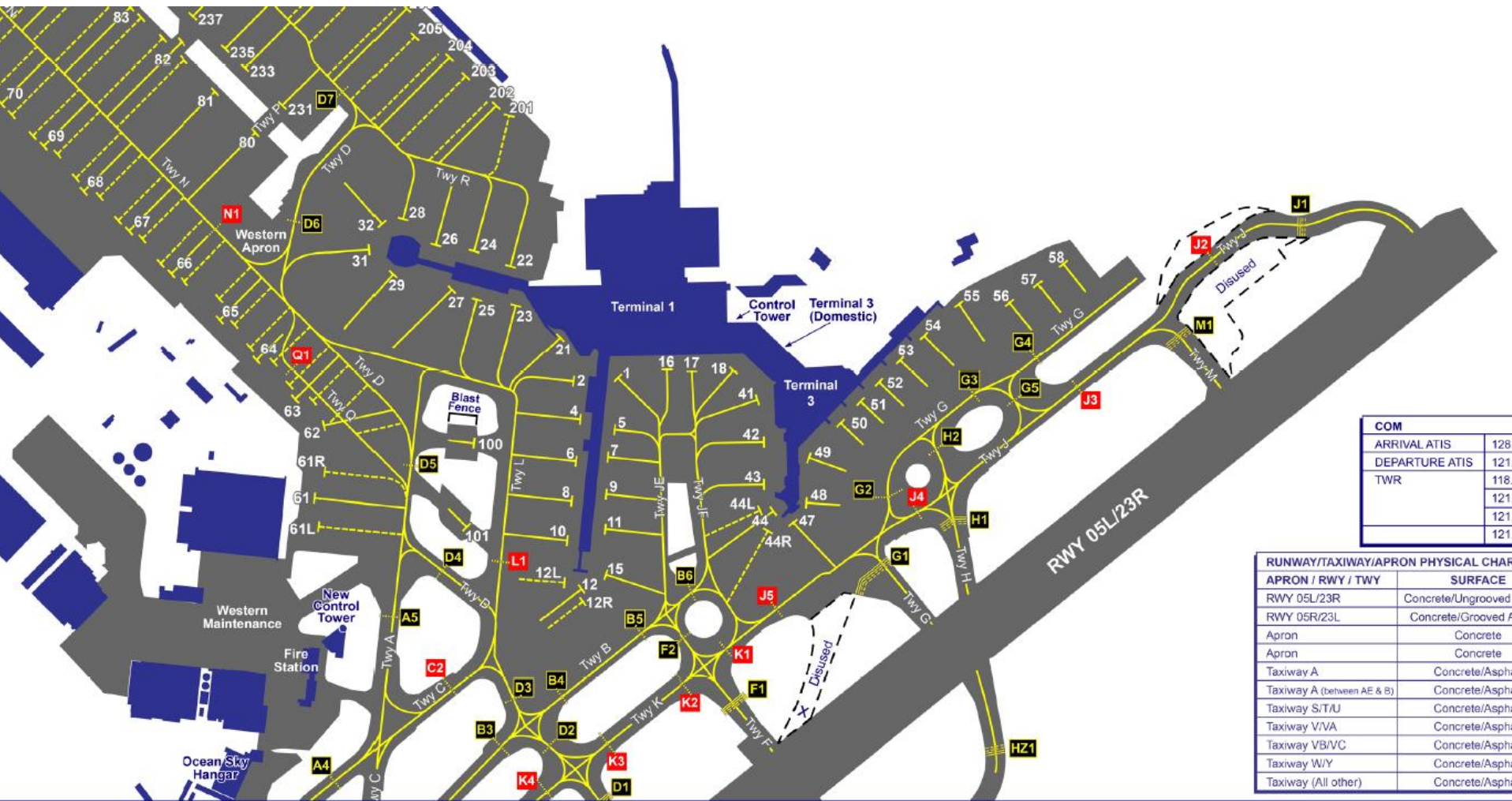

COM	
ARRIVAL ATIS	128.
DEPARTURE ATIS	121.
TWR	118.
	121.
	121.

RUNWAY/TAXIWAY/APRON PHYSICAL CHARACTERISTICS	
APRON / RWY / TWY	SURFACE
RWY 05L/23R	Concrete/Ungrooved
RWY 05R/23L	Concrete/Grooved
Apron	Concrete
Apron	Concrete
Taxiway A	Concrete/Asph
Taxiway A (between AE & B)	Concrete/Asph
Taxiway S/T/U	Concrete/Asph
Taxiway V/V/A	Concrete/Asph
Taxiway V/B/V/C	Concrete/Asph
Taxiway W/Y	Concrete/Asph
Taxiway (All other)	Concrete/Asph



Low Wiesorek

BAW11J
British Airways

LHR → ?
London

3D

Aircraft	Boeing 747-436	(B744)
Registration	G-CIVR	(4006A8)
Altitude	0 ft	Vertical Speed 0 fpm
Speed	20 kt	Track 265°
Latitude	51.475	Longitude -0.445

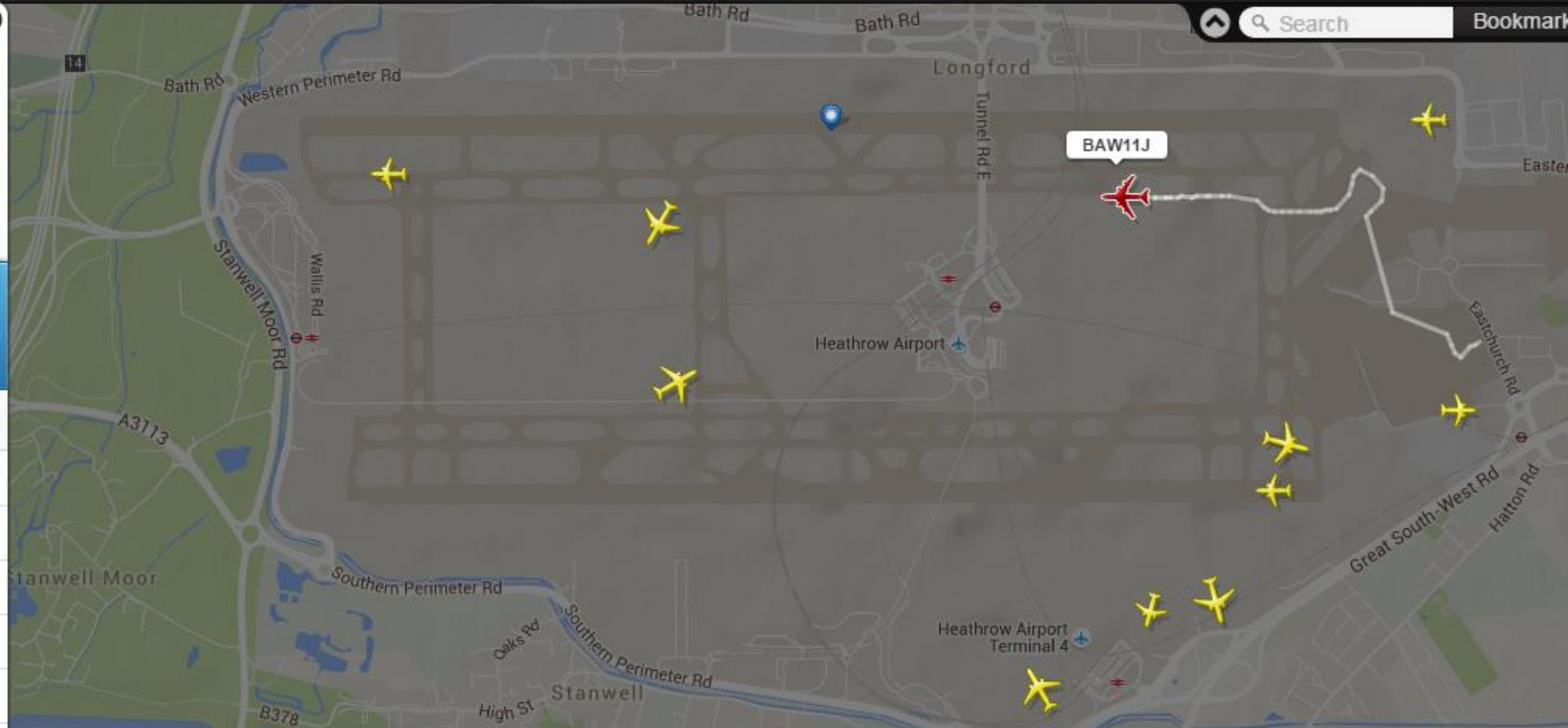

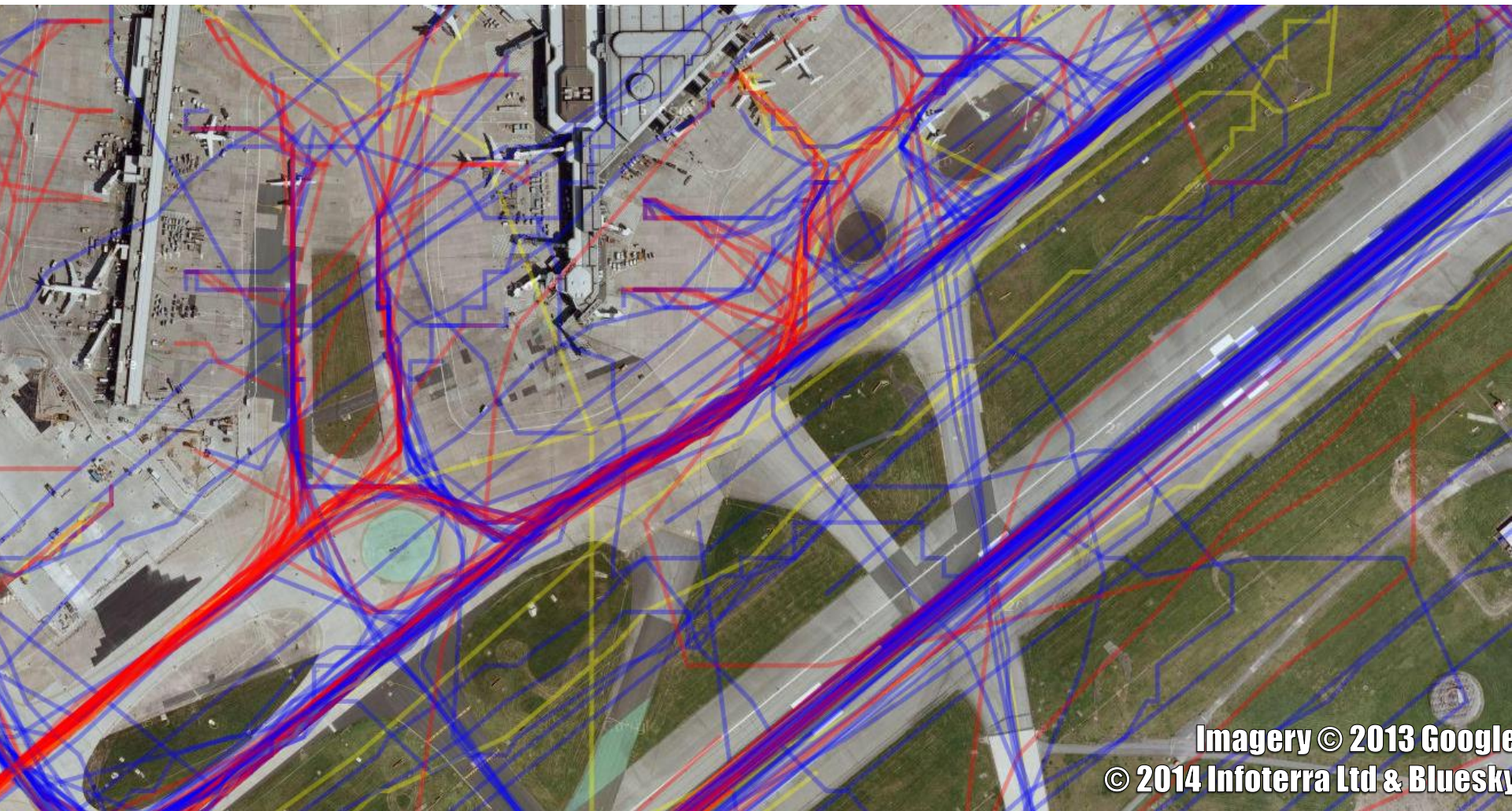

Imagery © 2013 Google
© 2014 Infoterra Ltd & Bluesky

Cleaning

1. Clean bad coords
2. Locate edges
3. Refine selection
4. Complete route
5. Remove branches
6. Success?
 1. Calc times
 2. Split route?
7. Fail?
 1. Displace coords



What we got...

Airport	Tracks	Add 1	Disc.	To snap	Snapped	Add 2	Out	% of FR24	% of actual
CGN	4473	0	2337	2136	1294	4	1298	28.9% of 4499	17.7% of 7346
EDI	4851	0	207	4591	3358	2	3360	69.3% of 4851	43.9% of 7662
MAN	1760	110	79	1791	1416	4	1420	80.4% of 1767	44.2% of 3211
MEL	8474	0	2409	6065	4801	0	4801	55.7% of 8617	52.2% of 9194
STR	4986	0	598	4388	2831	2	2833	56.5% of 5018	40.2% of 7056
SVO	9709	41	4641	5109	1755	1	1756	17.9% of 9810	11.0% of 15913
ZRH	19707	0	6313	13394	10320	50	10370	52.2% of 19871	40.3% of 25754

- Analysis of:
 - Taxi routes
 - Stand preferences
 - Operating modes
 - Taxi speeds + times (and uncertainty)
- Over a whole period, or sub-periods

Modelling taxi times

- Existing Mamdani FRBS

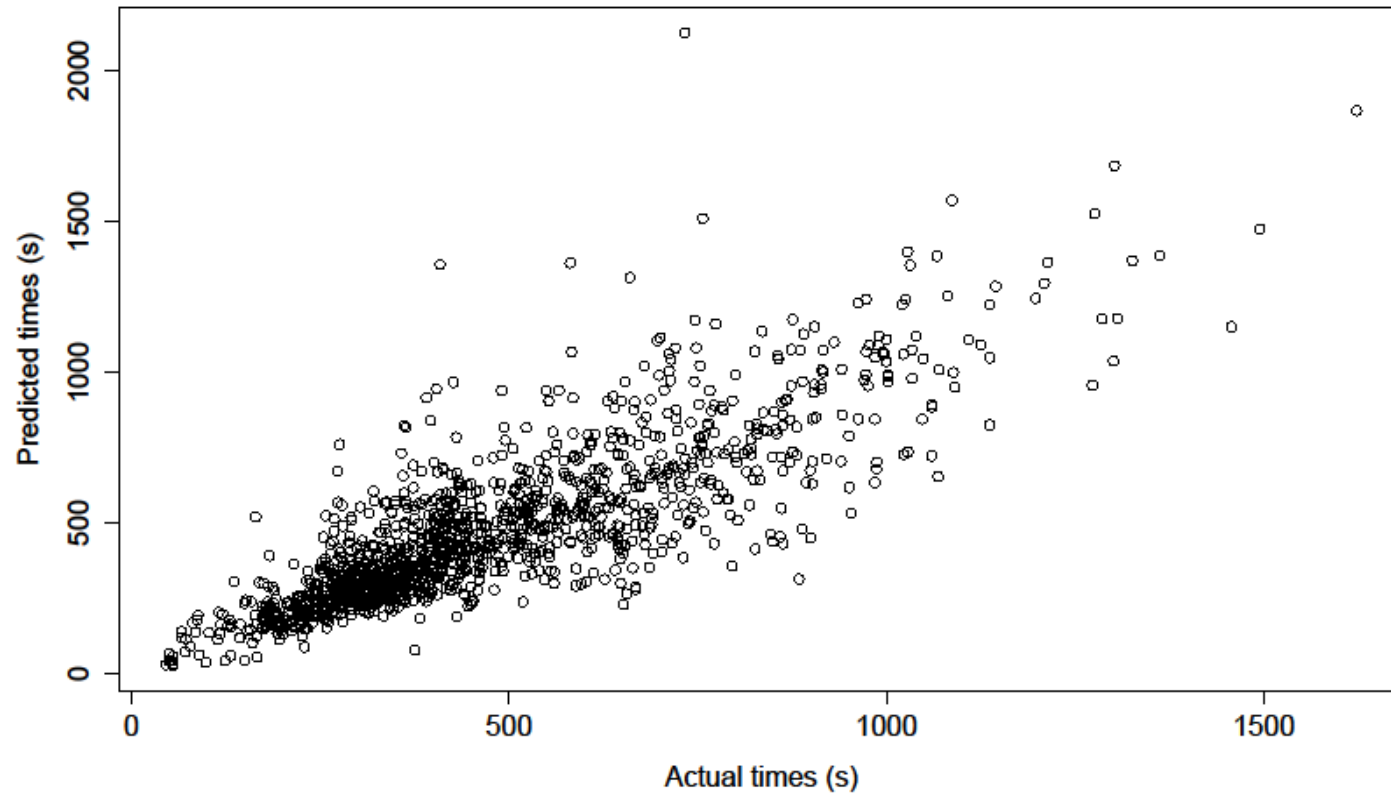

Taxi time uncertainty

- Taxi times for individual edges are quite variable:

24-VA-TAXIWAY NINTERSECTION-N25255972()>NINTERMEDIATE-N37974

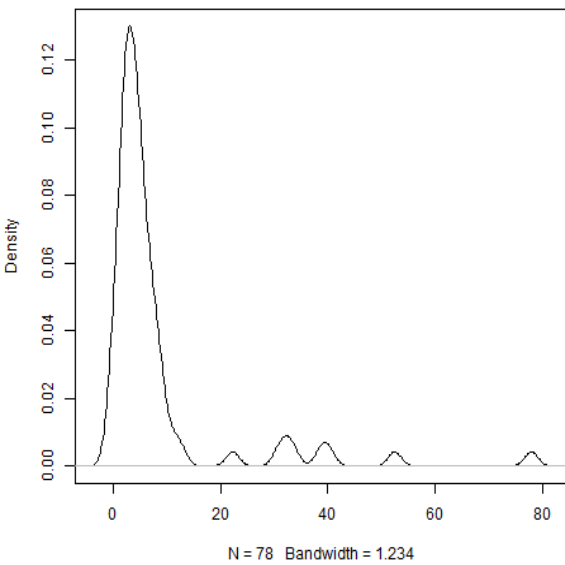

10-B-TAXIWAY NINTERSECTION-N280703819()>NINTERMEDIATE-N15113

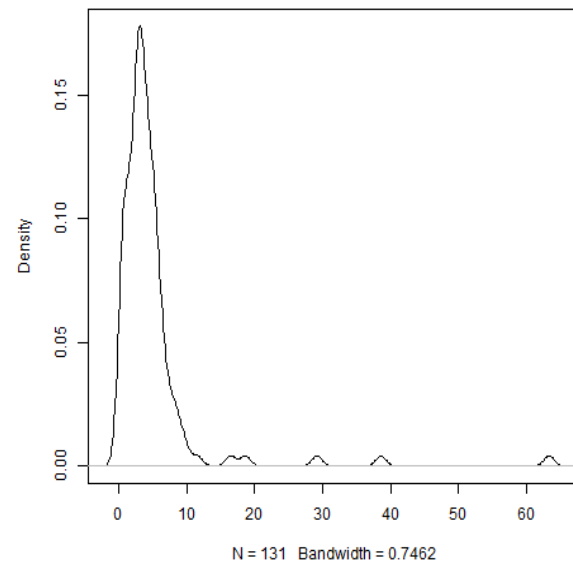

1-B-TAXIWAY NINTERMEDIATE-N1511314328()>NINTERMEDIATE-N15113

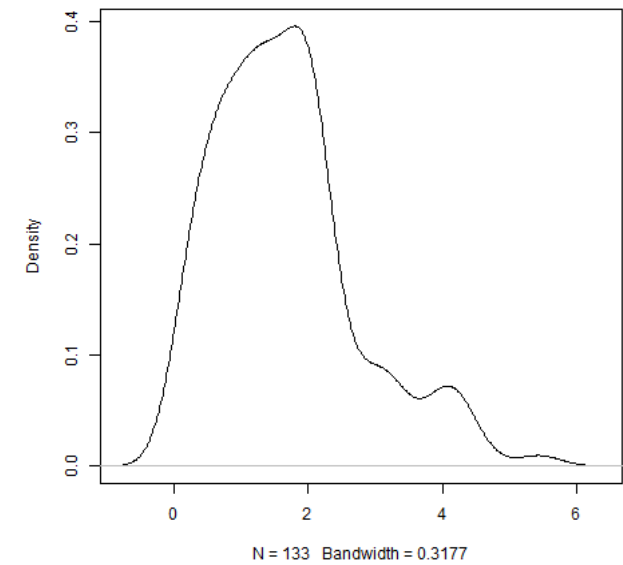

Better modelling

- Using random forests & gradient boosting regressors
- Analysis of variables comes "for free"
- Throw in as many variables as we can!

Better modelling

Departure/Arrival

Distance

Distance on long straights

Total turn angle

Better modelling

Operating mode (which runways in use)

Number of departures currently taxiing

Number of departures recently stopped taxiing

Number of arrivals currently taxiing

Number of arrivals recently stopped taxiing

Better modelling

Pressure

Visibility

Temperature

Wind speed

Rain/Snow/Drizzle/Hail

Fog/Mist/Haze

Better modelling

Average speed of last 5, last 10:

Departures

Arrivals

All aircraft

?

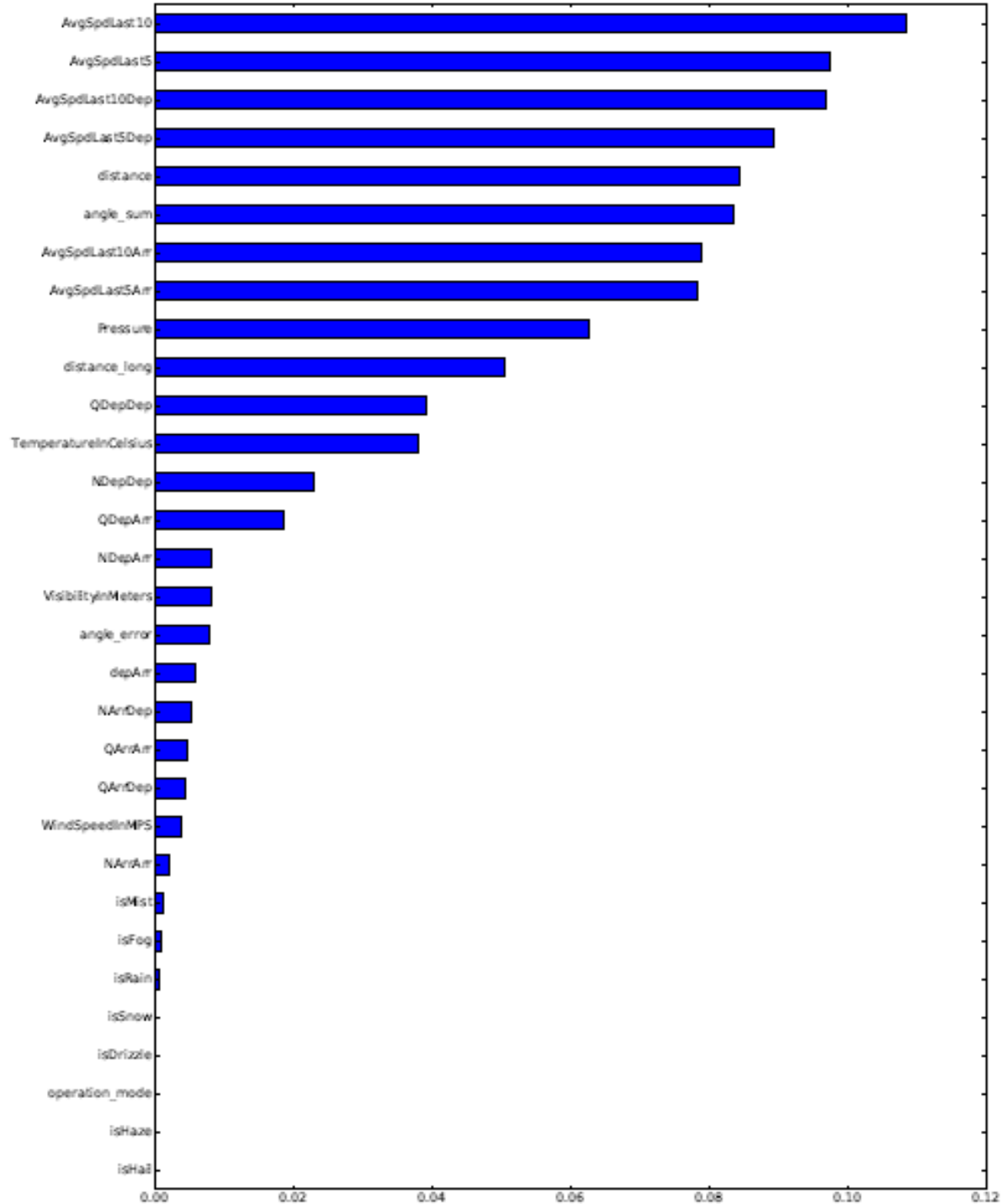

Better modelling

Feature set	Manchester	Zurich	Hong Kong
Original	0.699	0.853	0.925
Orig+Weather	0.720	0.859	0.926
Orig+Weather+avgspd	0.723	0.871	0.942
Cutdown	0.480	0.453	0.744

Picture is complicated!

Now running automated feature selection

Route optimisation

- Followed two tracks
 - Integration of taxi routing and runway sequencing
 - Adapting routing algorithm to handle uncertainty
- Routing algorithm follows two broad stages
 - Core algorithm is *Quickest Path Problem with Time Windows (QPPTW)*: adaptation of Dijkstra's shortest path algorithm, but with the addition of a time dimension to avoid conflicts between aircraft
 - Outer layer sorts aircraft for routing by QPPTW

Routing algorithm - QPPTW

Example:
Route two
aircraft from
C to E, both
starting at
time 0

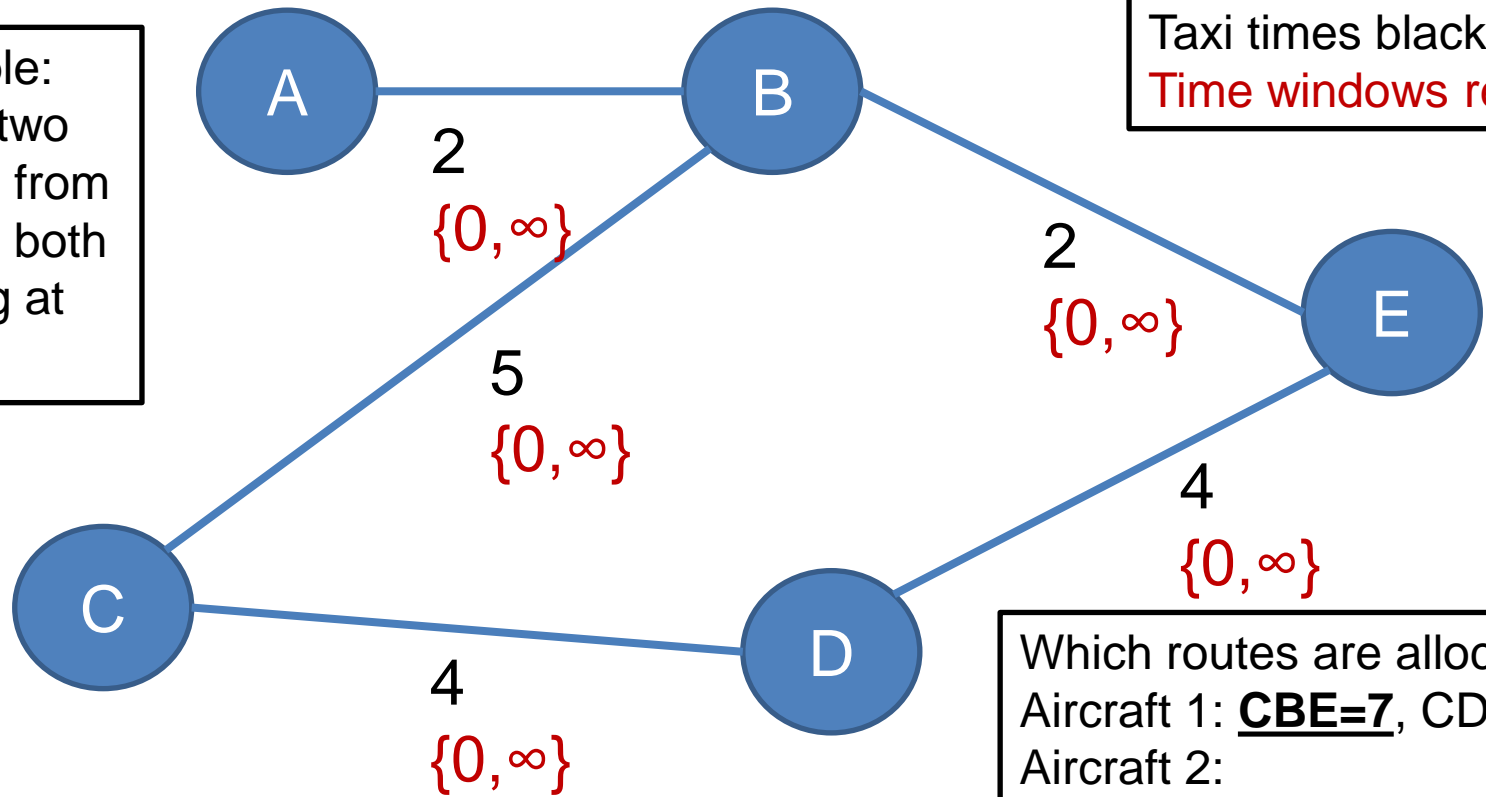

Routing algorithm - QPPTW

Example:
Route two
aircraft from
C to E, both
starting at
time 0

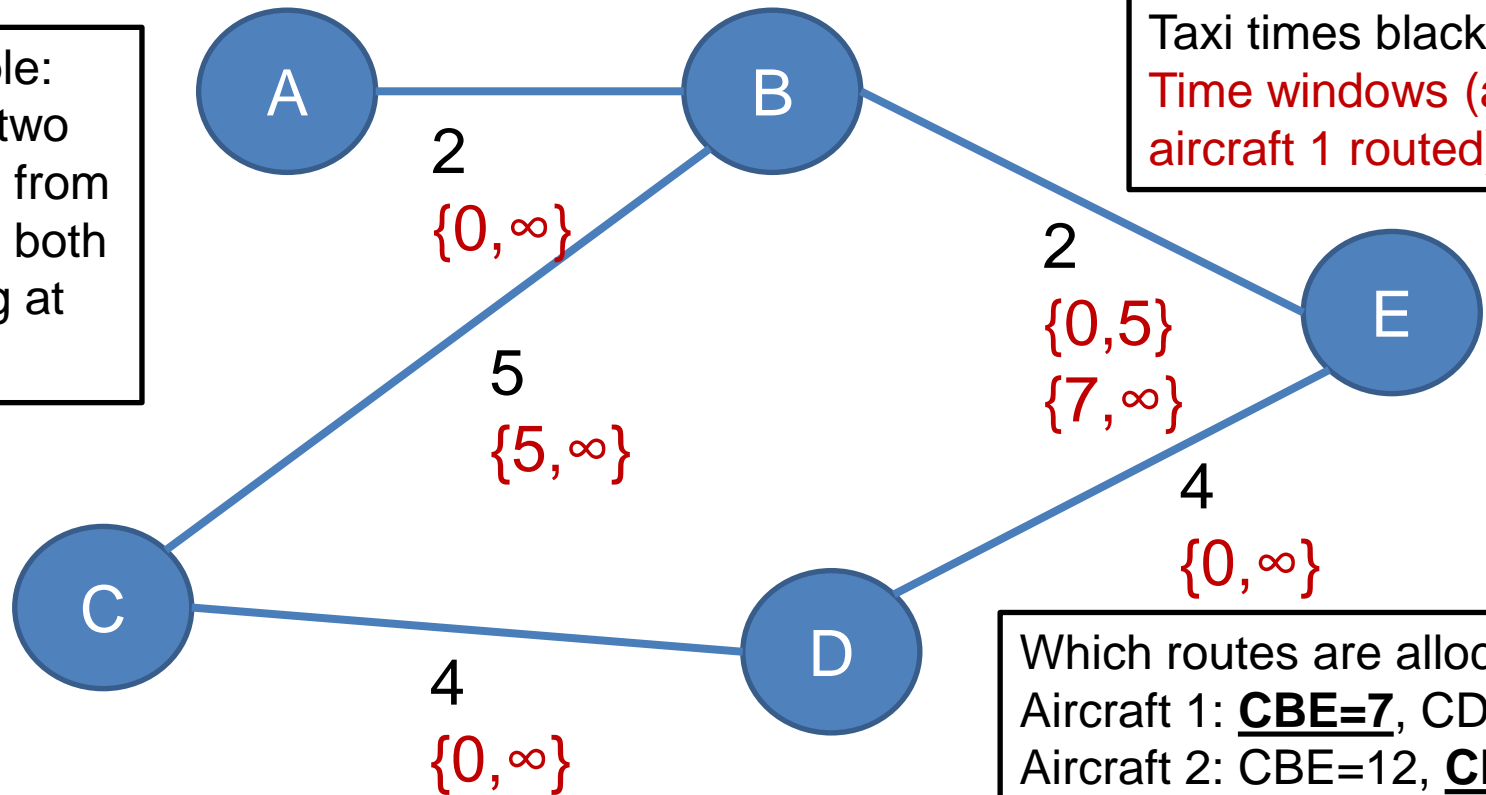

Handling uncertainty

- Adapted QPPTW to use fuzzy rather than crisp times
- Multiple routes generated for each aircraft under different levels of uncertainty

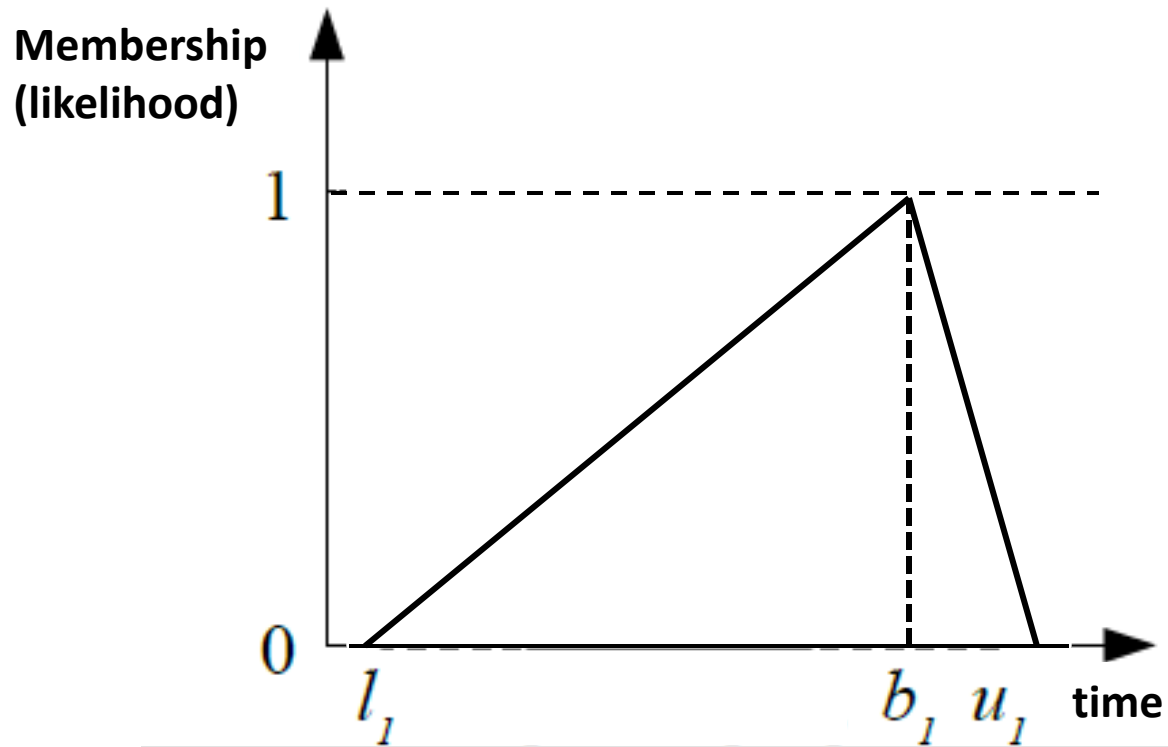

Handling uncertainty

- Adapted QPPTW to use fuzzy rather than crisp times
- Multiple routes generated for each aircraft under different levels of uncertainty

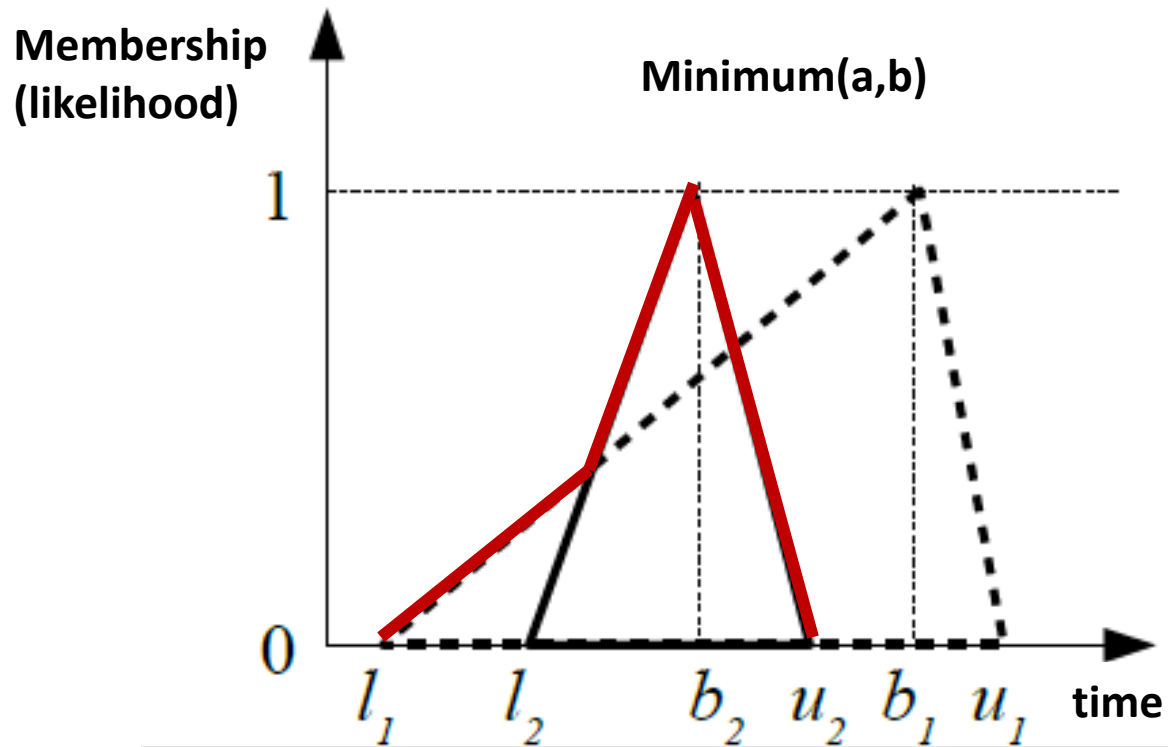

Handling uncertainty

- Adapted QPPTW to use fuzzy rather than crisp times
- Multiple routes generated for each aircraft under different levels of uncertainty

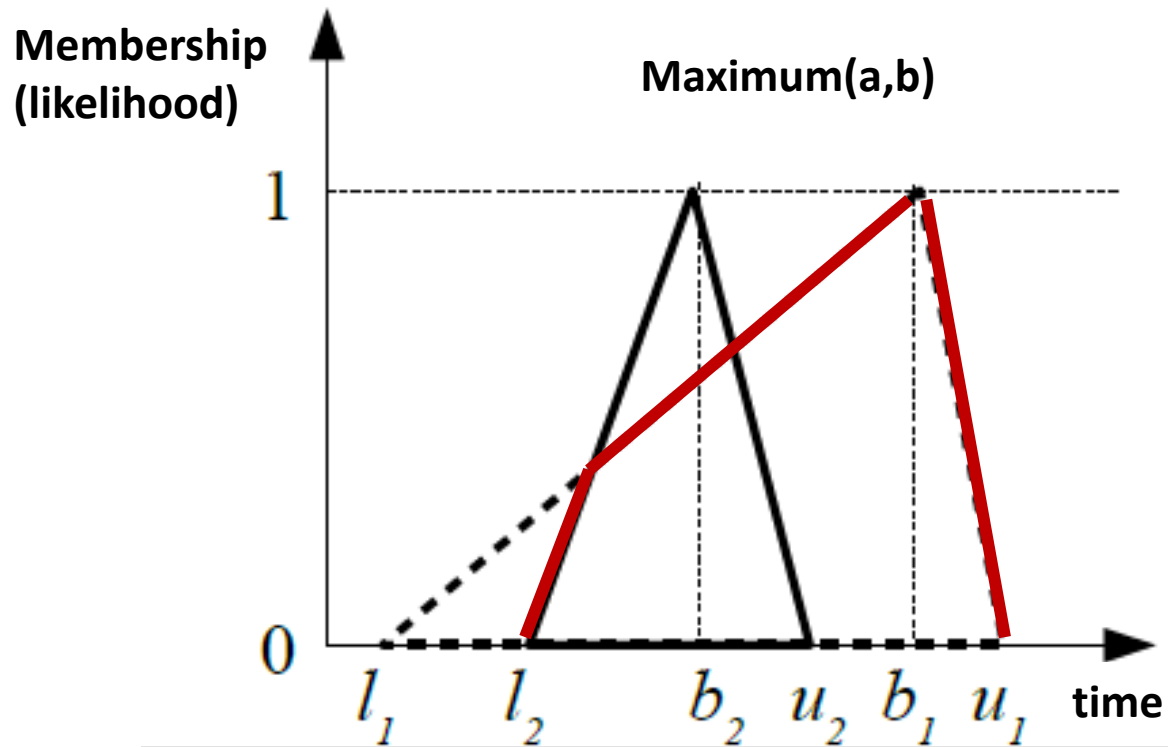

Handling uncertainty

- Adapted QPPTW to use fuzzy rather than crisp times
- Multiple routes generated for each aircraft under different levels of uncertainty

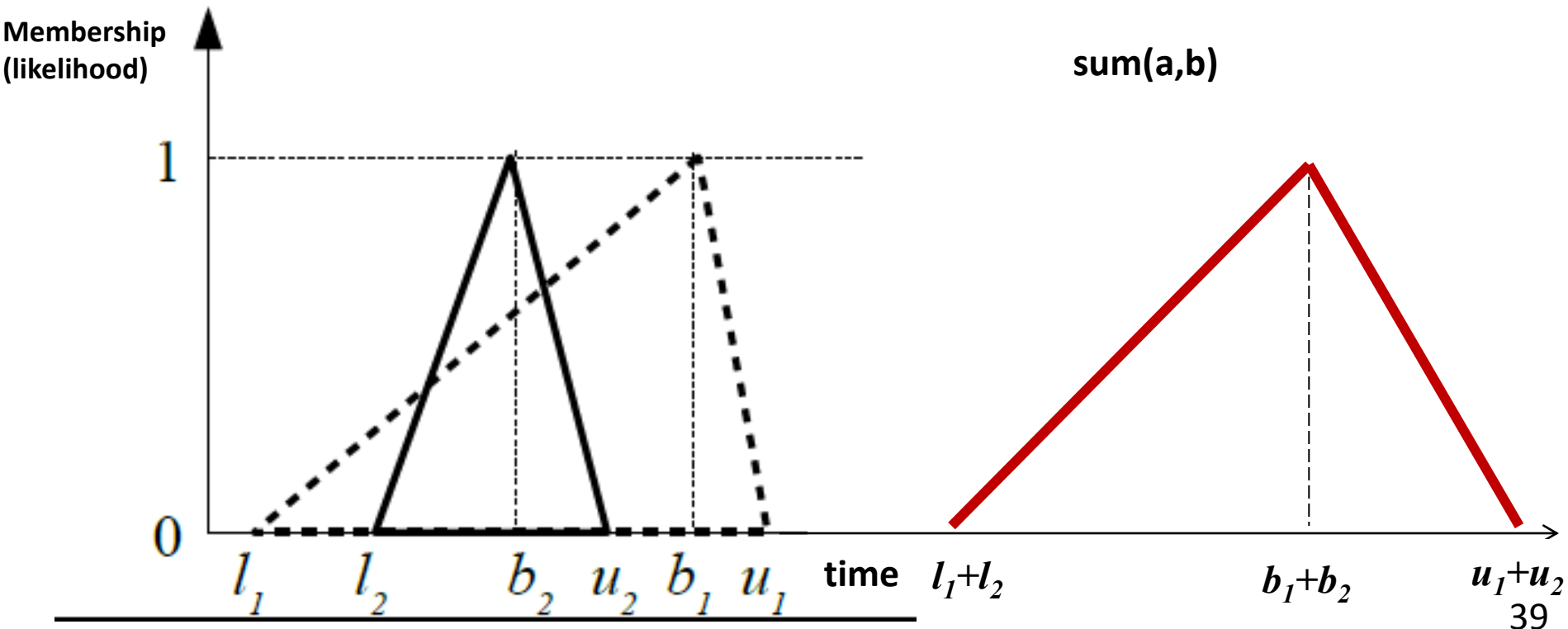

Handling uncertainty

- Route with end time having lowest CoG chosen

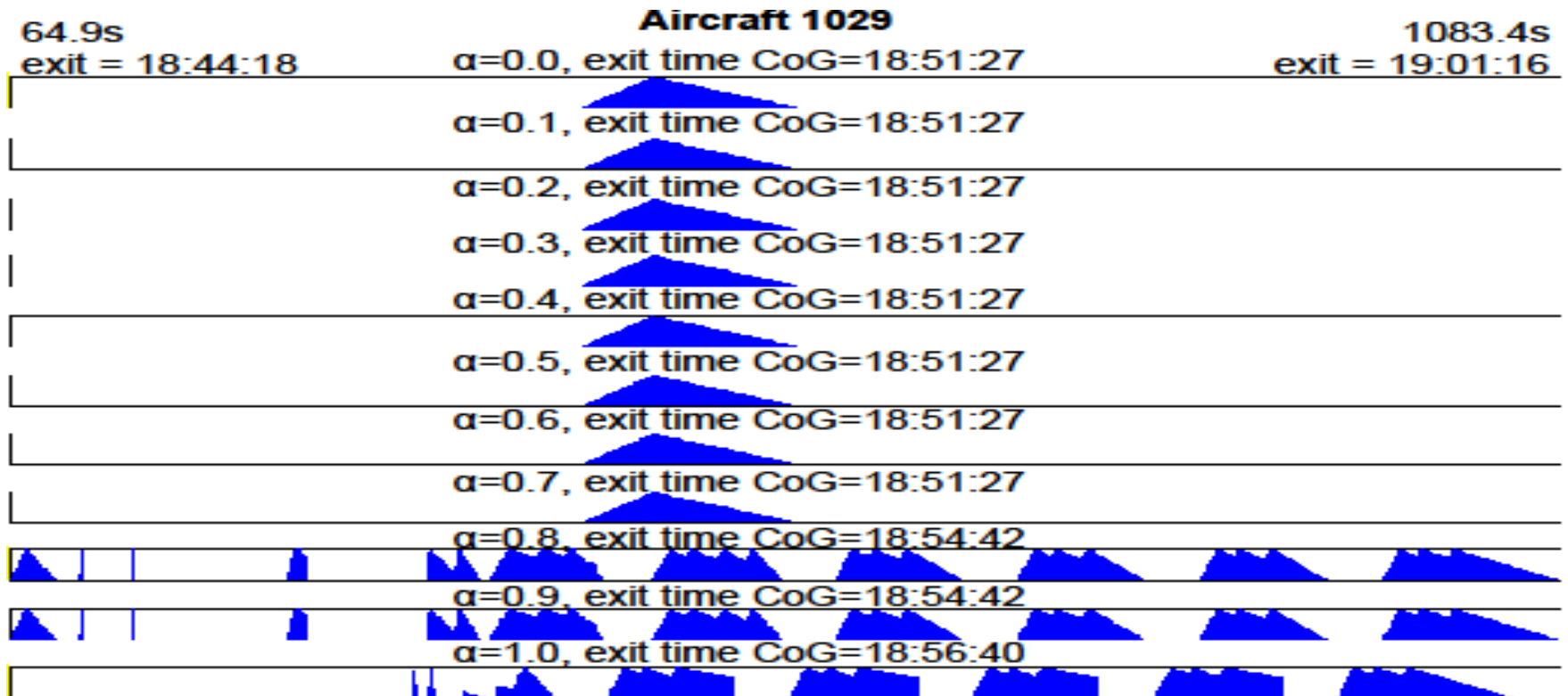

Measuring uncertainty

- Developed simulator to replicate aircraft movements and measure impact of different approaches on delays

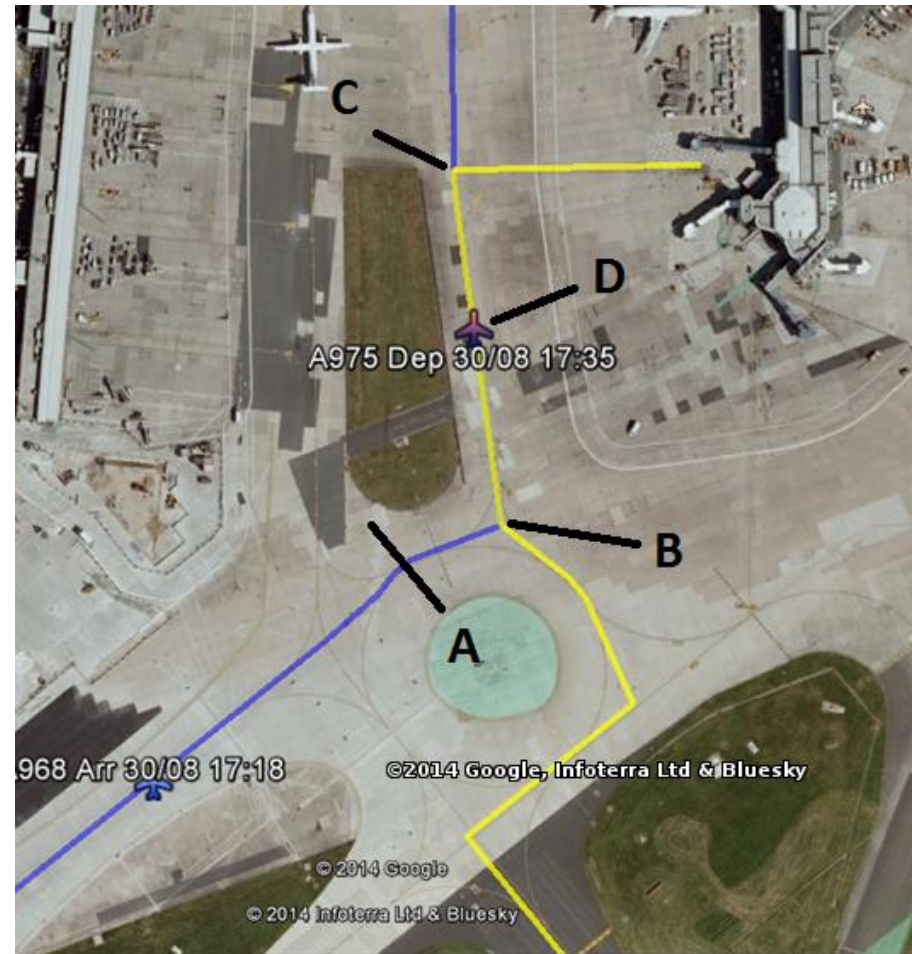

Results

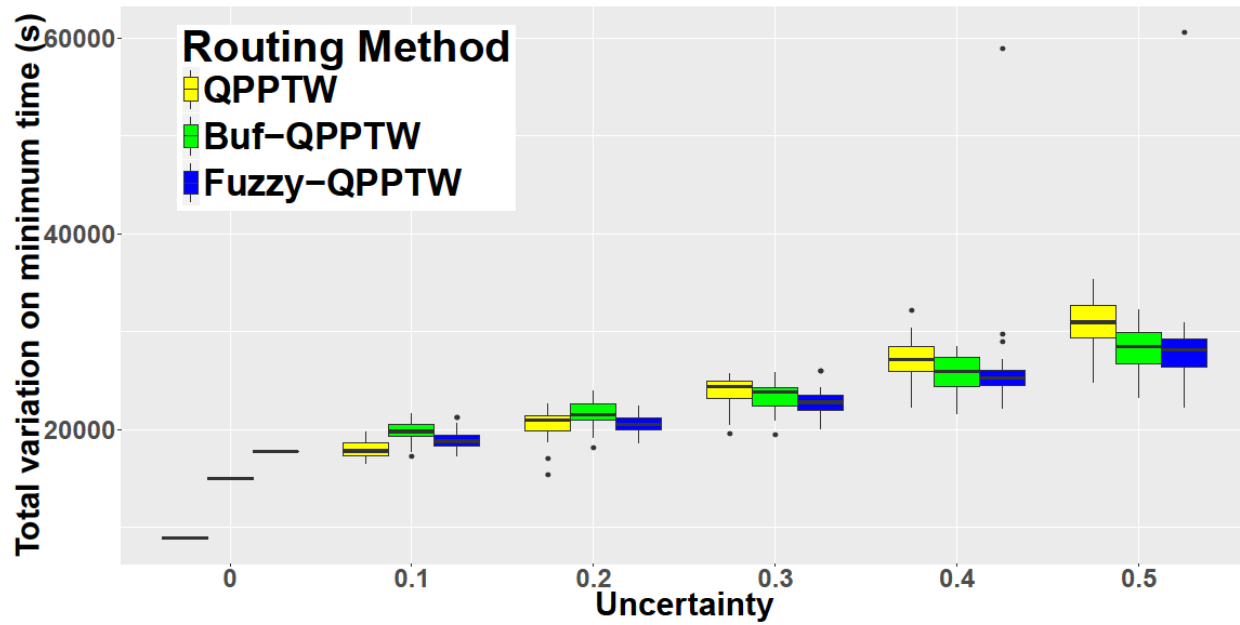
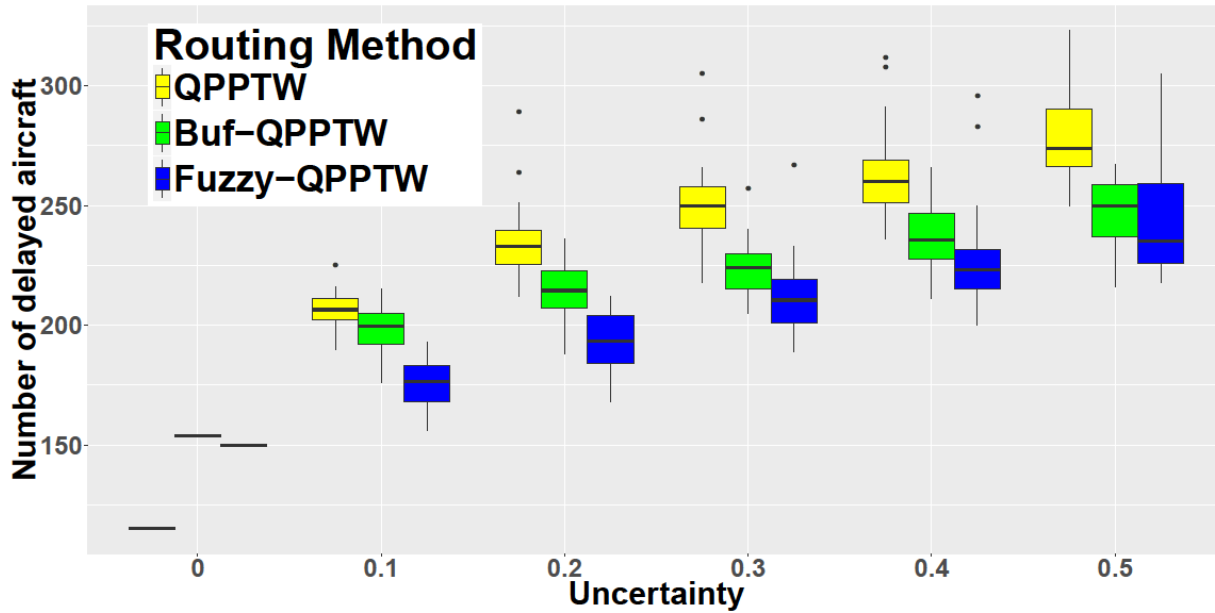

Fuzzy-QPPTW

- Fuzzy-QPPTW produced **more conservative** taxi routes: 1-2% longer in distance on average
- Routes **more robust**: less disrupted by uncertainty in the taxi times and reducing delays due to other aircraft by 10-20%
- **Less stopping and starting** of taxiing aircraft, reducing fuel consumption
- Ultimately a strategic decision on the preferred point in the trade-off between faster or more predictable routes

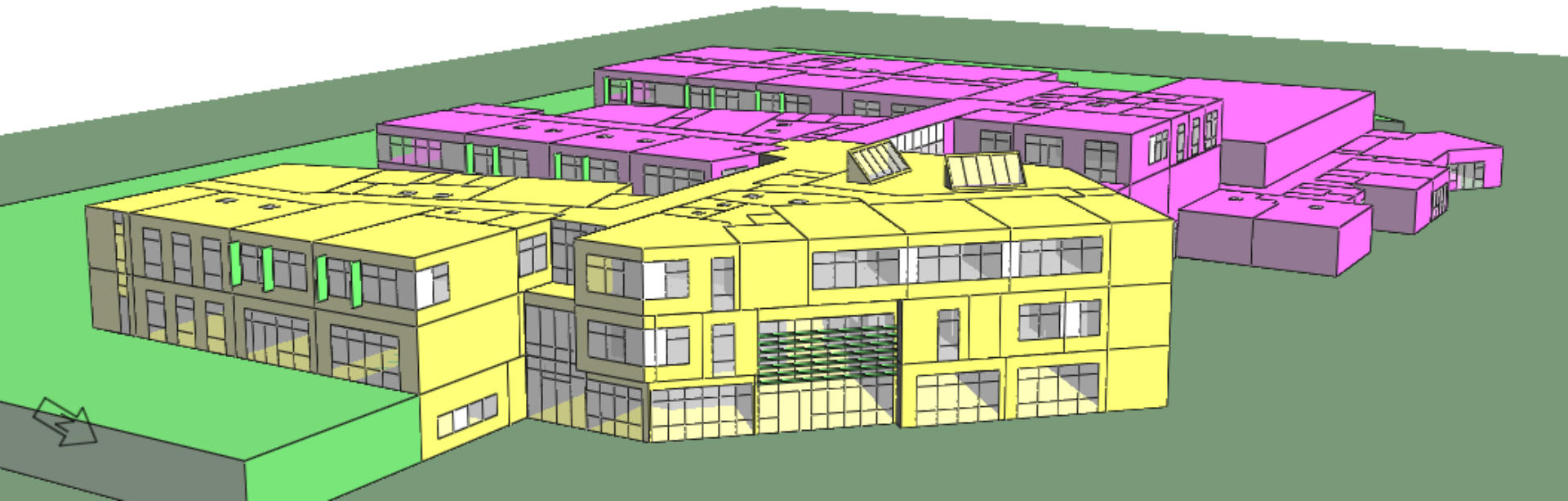

BUILDINGS

Building designs

- Why optimise?
- Climate change!
 - Over 50% of UK carbon emissions are related to energy consumed buildings
- Cost, comfort
- No mass production

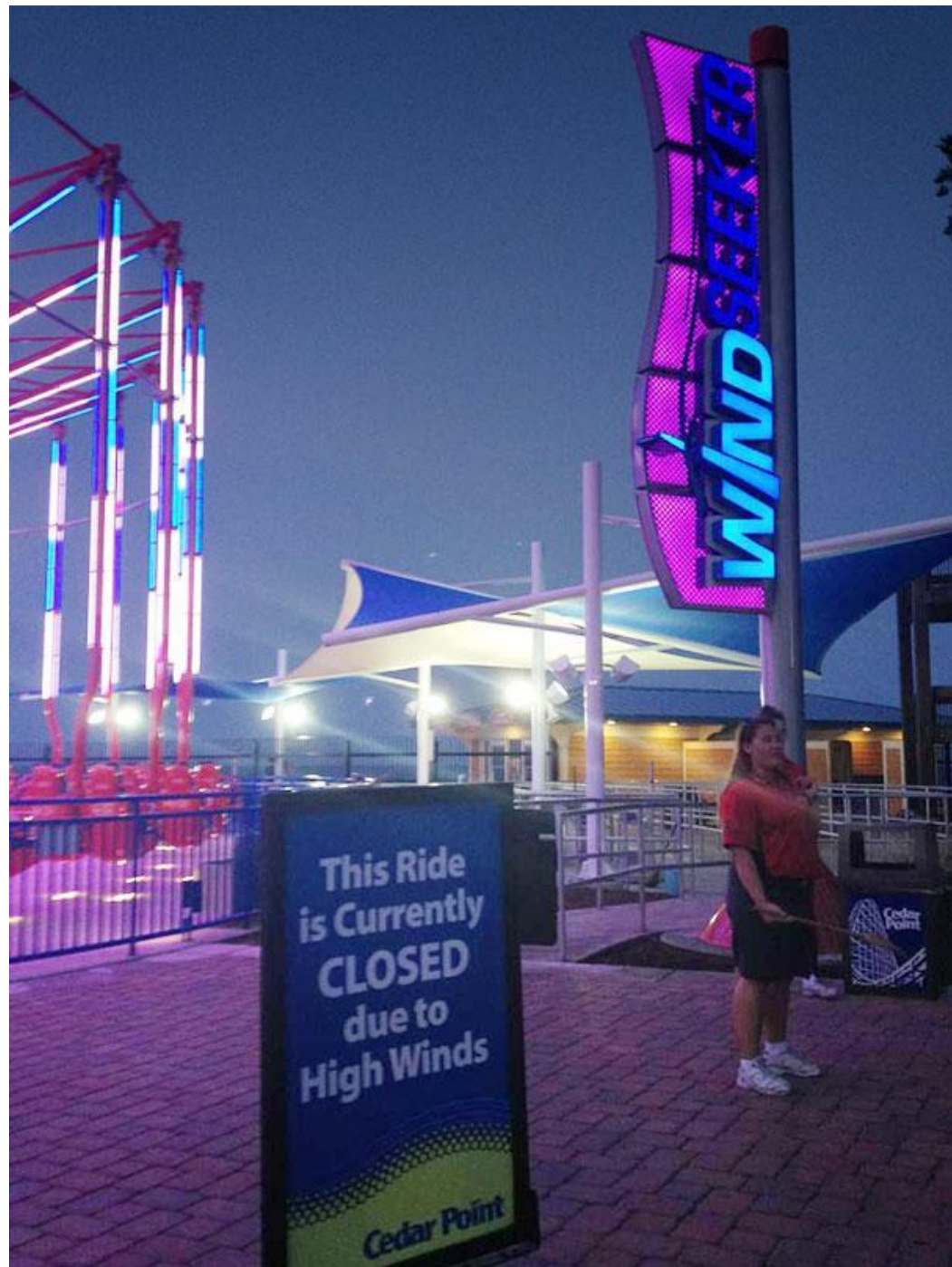

Building design optimisation

- Buildings are complex!
- Many variables
 - Dimensions, materials, layout, systems (heat / light etc), control configuration
- Many objectives / constraints
 - Energy use, Construction cost, Comfort
 - Compliance
- Highly suitable for evolutionary algorithms

Building design optimisation

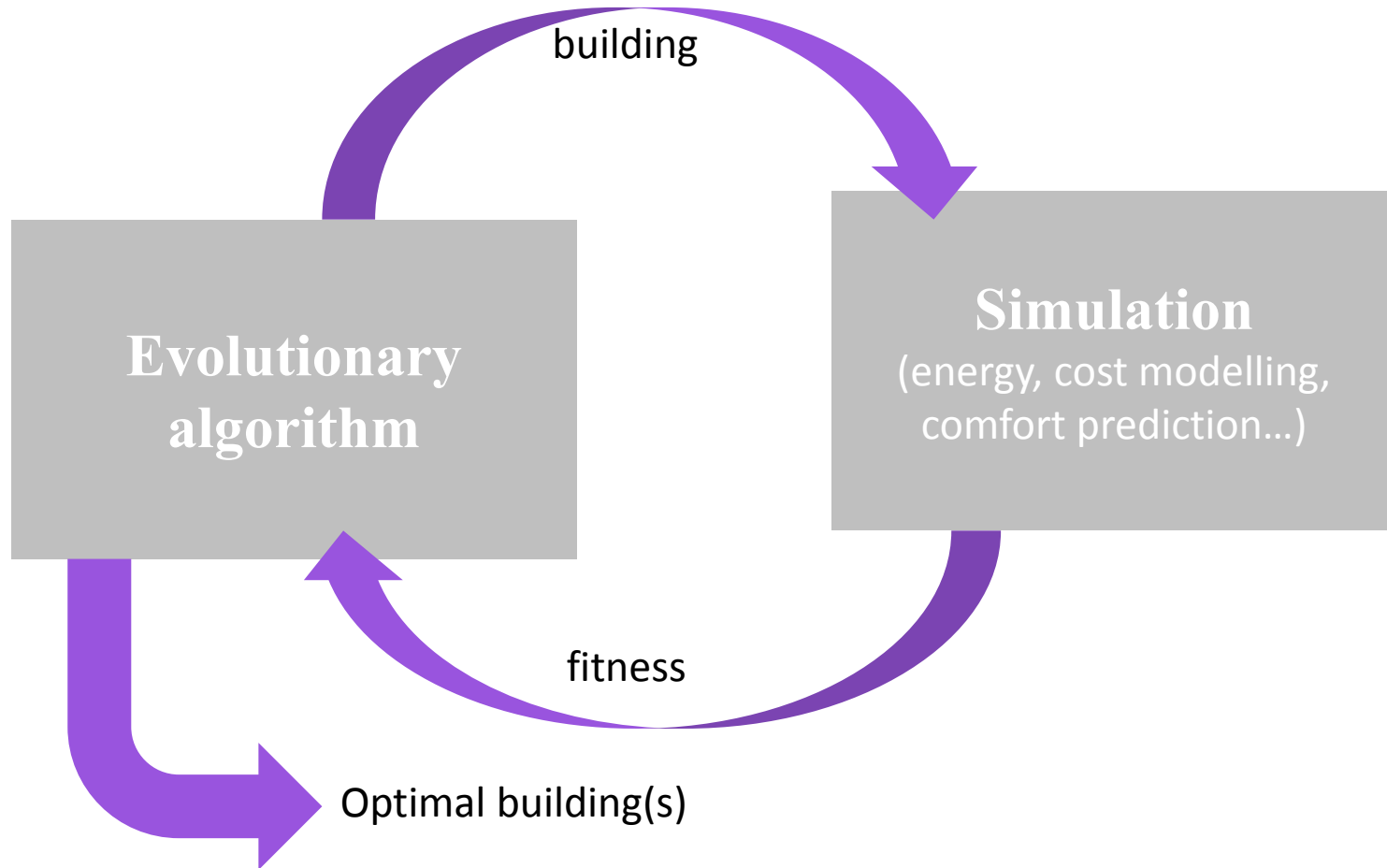

SO GA Example

0	1	1	1	0	1	4
1	0	1	1	0	0	3
0	0	1	1	0	1	3
0	1	1	0	1	0	3
0	0	0	0	1	1	2
1	0	0	0	0	0	1

0	1	1	1	0	1
1	0	1	1	0	0

0	1	1	1	0	0
1	0	1	1	0	1

0	1	1	1	0	0	3
1	0	1	1	1	1	5
1	0	1	1	1	0	4
0	1	1	0	0	1	3
1	0	1	0	0	0	2
0	0	0	0	1	0	1

0	1	1	1	0	0
1	0	1	1	1	1

Multi-objective

- Multi-objective optimisation...
- In reality, most problems are multi-objective, often with conflicts – e.g. cost vs performance
- How do we define fitness for more than one objective?
- Could just add them together, but how do we weight them?
- Better to find the trade-off and make an informed decision

Definition: Dominance

- This time there are two “fitnesses” (objective values) for each solution

0	1	1	1	0	1	1	3
1	0	1	1	0	0	2	4
0	0	1	1	0	1	4	6
0	1	1	0	1	0	3	7
0	0	0	0	1	1	2	2
1	0	0	0	0	0	4	1

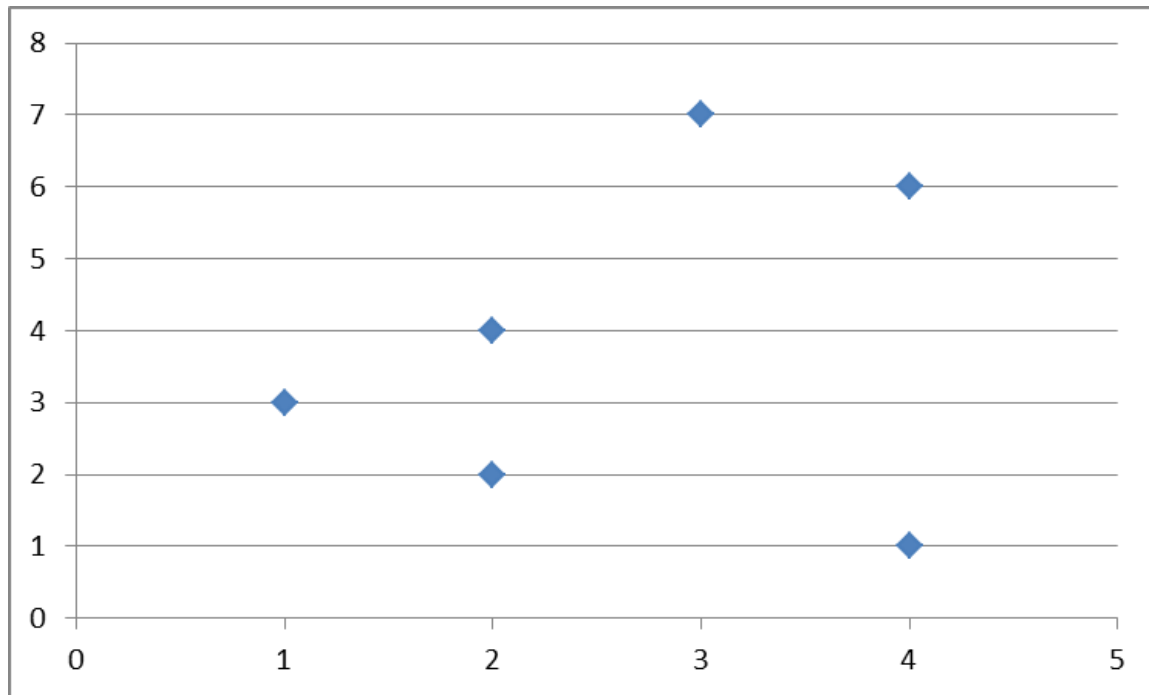

Constraints

- Some solutions “good” or “bad”
 - Building with no ventilation is cheap and low-energy, but not very comfortable!
 - E.g.: max hours over 28°C, min lighting, compliance with law
- How to handle?
 - Whole research area
 - Can be included in the concept of dominance
- Constraints can be hard to satisfy



Example

- Small 5 zone office; a single floor of a larger building
- **Variables:**
 - Orientation, glazing area, type, wall/floor types, HVAC set points and times
- **Objectives:**
 - Energy use, cap cost
- **Constraints:**
 - Thermal comfort, air quality (CO₂ levels)

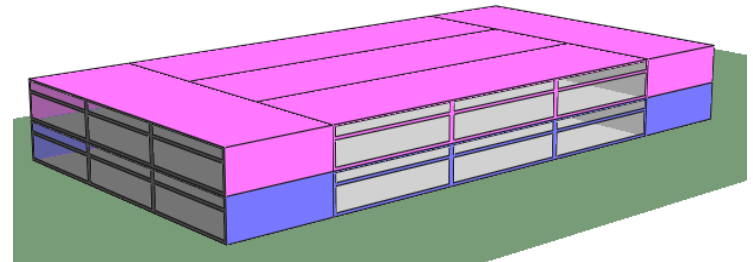

Results

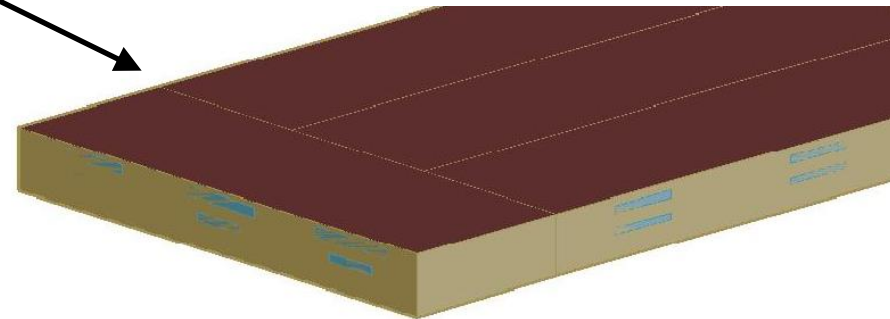
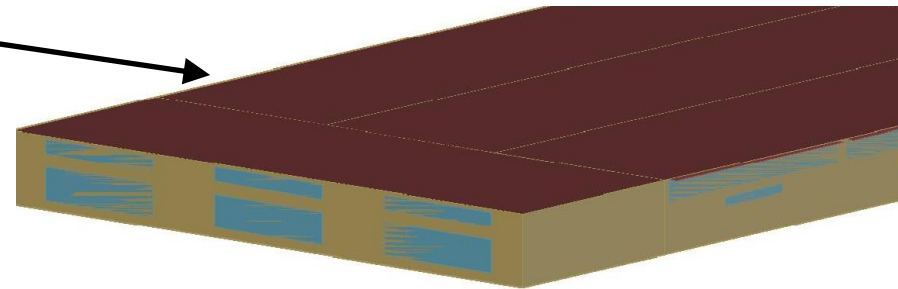
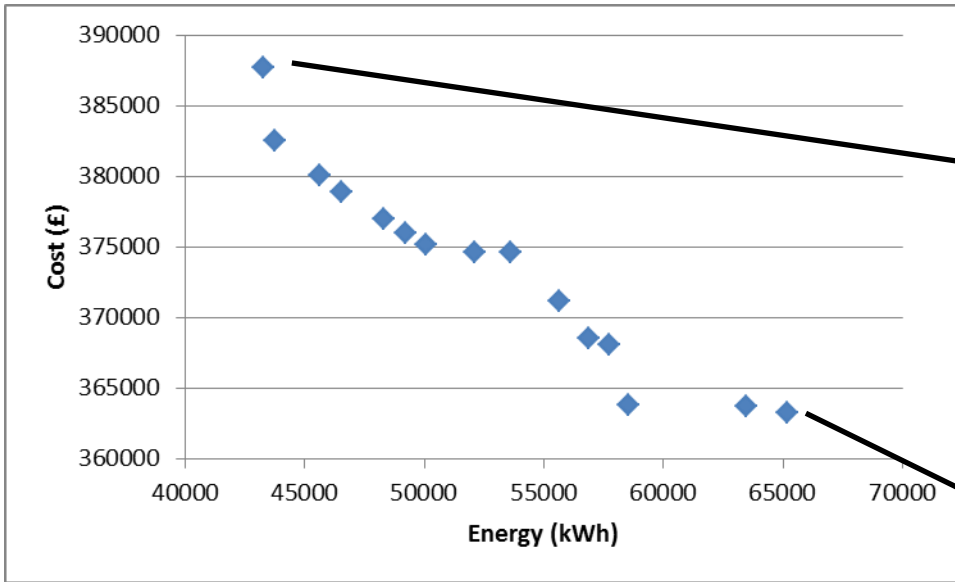

Results

Example building with glazing altered

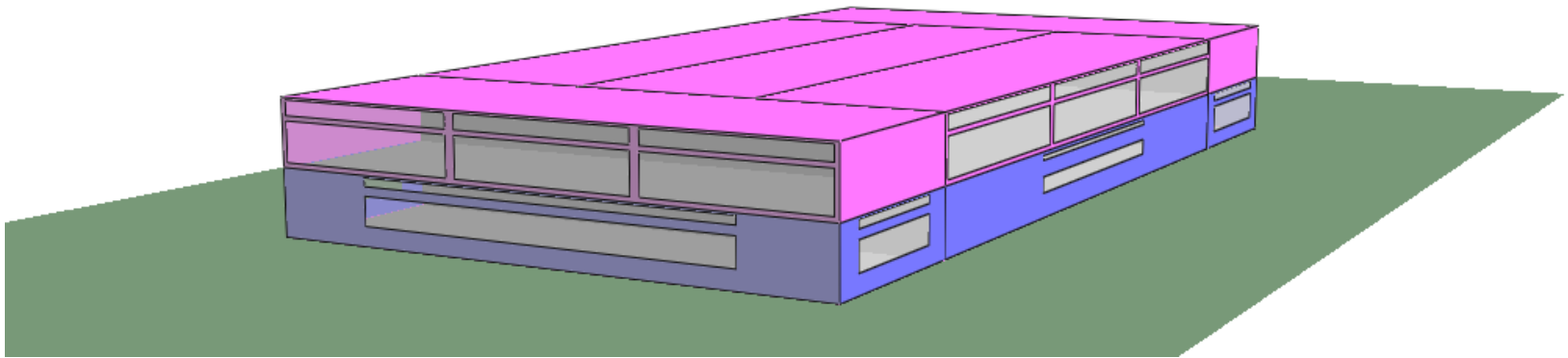

Variable sensitivity – decision making

- Decision making
 - *Why* is a given solution optimal?
 - *How optimal* is a given solution?
 - *What* design decisions actually impact on the objectives?
- Observe which variables impact the most
 - Can we ignore some of them to simplify the search?
 - What do we learn about the underlying problem?
Can this aid decision making?

Variable sensitivity

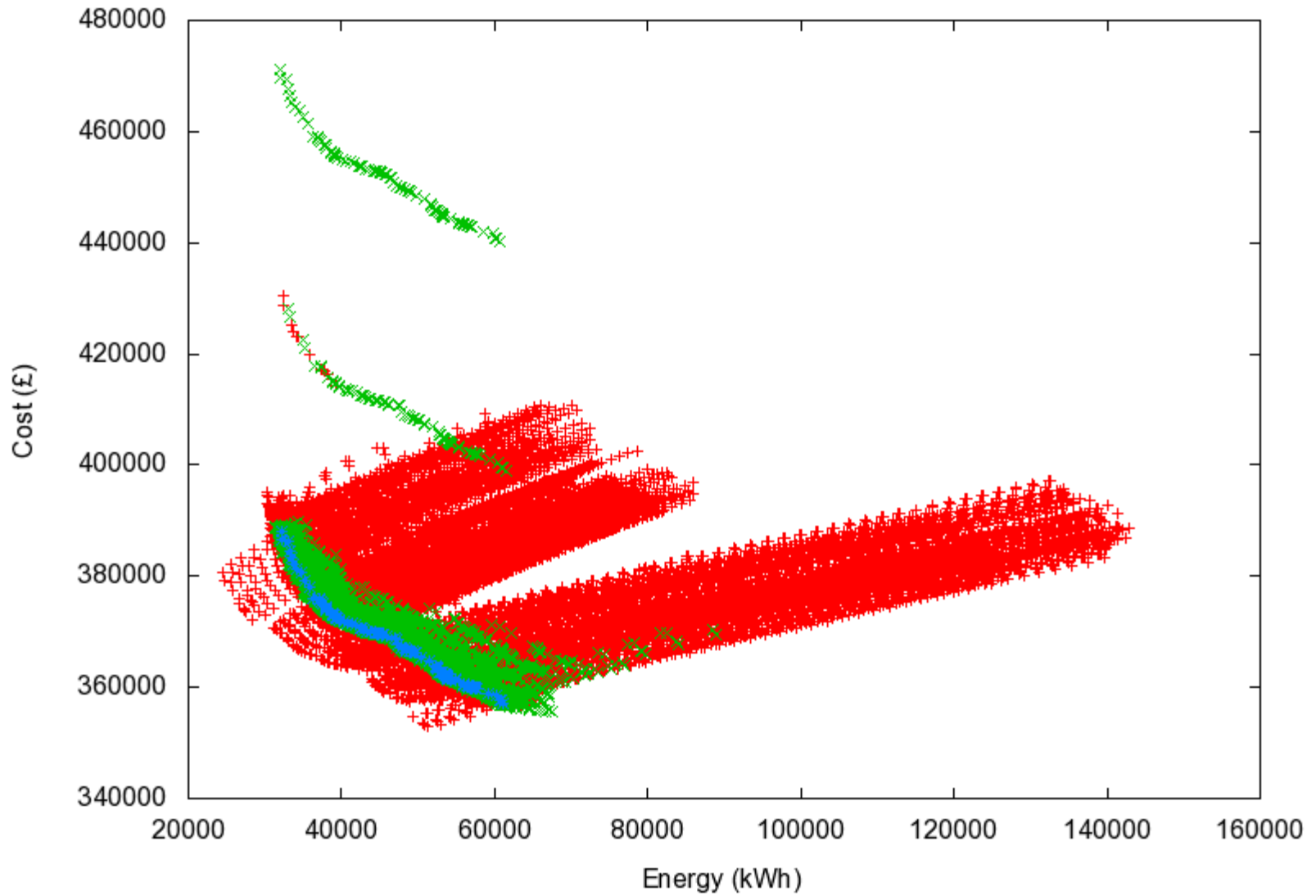

Infeasible + Feasible x GlobalPF *

Variable Sensitivity

- A – HVAC heating set point
- B – HVAC cooling set point
- C – threshold temp for nat. vent.
- D – glazed area, north upper
- E – glazed area, south upper
- F – mechanical ventilation rate
- G – external wall material
- H – ceiling and floor material
- I – shading overhang present

Energy	CapCost	A	B	C	D	E	F	G	H	I
0.00	1.00	0.5	0.564516	0.98	0.65	0.82	0.11	0	1	1
0.01	0.90	0.5	0.564516	0.98	0.65	0.79	0.11	0	1	1
0.03	0.82	0.5	0.580645	0.98	0.57	0.79	0.11	0	1	1
0.04	0.76	0.5	0.580645	0.98	0.49	0.79	0.11	0	1	0
0.07	0.74	0.5	0.564516	0.98	0.49	0.79	0.11	0	1	0
0.07	0.70	0.5	0.564516	0.98	0.49	0.79	0.22	0	1	0
0.10	0.66	0.5	0.580645	0.98	0.41	0.79	0.11	0	1	0
0.10	0.62	0.5	0.564516	0.98	0.65	0.82	1.00	1	1	1
0.10	0.61	0.5	0.564516	0.98	0.65	0.82	0.11	1	1	1
0.10	0.61	0.5	0.564516	0.98	0.65	0.82	1.00	1	1	1
0.12	0.59	0.5	0.612903	0.98	0.65	0.82	0.67	1	1	1
0.14	0.57	0.5	0.548389	0.98	0.49	0.79	0.11	1	1	0
0.15	0.54	0.4	0.548389	0.98	0.57	0.79	0.67	1	1	0
0.17	0.53	0.4	0.548389	0.98	0.57	0.79	0.67	1	1	0
0.18	0.52	0.5	0.564516	0.98	0.49	0.79	0.11	1	1	0
0.18	0.49	0.4	0.548389	0.98	0.57	0.79	0.67	1	1	0
0.21	0.45	0.4	0.564516	0.98	0.41	0.43	0.11	0.5	1	0
0.21	0.43	0.5	0.564516	0.98	0.57	0.43	0.67	1	1	0
0.21	0.37	0.4	0.548389	0.98	0.49	0.43	0.67	1	1	0
0.24	0.35	0.4	0.548389	0.98	0.49	0.43	0.67	1	1	0
0.27	0.32	0.4	0.548389	0.98	0.41	0.43	0.11	1	1	0
0.32	0.30	0.4	0.548389	0.98	0.33	0.43	0.67	1	1	0
0.33	0.29	0.4	0.548389	0.98	0.33	0.43	0.11	1	1	0
0.35	0.27	0.4	0.580645	0.98	0.35	0.43	0.11	1	1	0
0.35	0.26	0.4	0.596774	0.98	0.24	0.43	0.11	1	1	0
0.36	0.25	0.4	0.548389	0.98	0.29	0.43	0.11	1	1	0
0.38	0.25	0.4	0.596774	0.98	0.33	0.33	0.11	1	1	0
0.39	0.25	0.4	0.596774	0.98	0.33	0.33	0.11	1	1	0
0.39	0.24	0.4	0.596774	0.98	0.33	0.33	0.11	1	1	0
0.41	0.20	0.4	0.596774	0.98	0.33	0.33	0.67	1	1	0
0.46	0.20	0.4	0.596774	0.98	0.33	0.33	0.11	1	1	0
0.46	0.20	0.4	0.596774	0.98	0.33	0.33	0.11	1	1	0
0.47	0.19	0.4	0.564516	0.98	0.24	0.33	0.11	1	1	0
0.49	0.18	0.4	0.596774	0.98	0.24	0.33	1.00	1	1	0
0.54	0.16	0.4	0.532298	1.00	0.24	0.33	0.11	1	1	0
0.55	0.14	0.4	0.596774	0.98	0.24	0.33	0.67	1	1	0
0.57	0.12	0.4	0.596774	0.98	0.24	0.33	0.11	1	1	0
0.64	0.11	0.4	0.612903	0.98	0.24	0.43	0.11	1	1	0
0.64	0.11	0.4	0.612903	0.98	0.33	0.33	0.00	1	1	0
0.65	0.09	0.4	0.596774	0.98	0.24	0.33	0.11	1	1	0
0.66	0.08	0.4	0.612903	0.98	0.24	0.33	0.11	1	1	0
0.67	0.08	0.4	0.612903	0.98	0.24	0.33	0.11	1	1	0
0.67	0.07	0.4	0.612903	0.98	0.24	0.33	0.11	1	1	0
0.70	0.07	0.4	0.612903	1.00	0.24	0.33	0.11	1	1	0
0.91	0.05	0.4	0.612903	0.98	0.33	0.04	0.11	1	1	0
0.92	0.04	0.4	0.596774	0.98	0.33	0.04	0.11	1	1	0
0.93	0.01	0.4	0.596774	0.98	0.29	0.04	0.11	1	1	0
0.97	0.01	0.4	0.612903	0.98	0.24	0.04	0.11	1	1	0
1.00	0.00	0.4	0.612903	1.00	0.24	0.04	0.11	1	1	0
Corr. with energy:		-0.76	0.63	0.32	-0.86	-0.93	-0.31	0.61	0.00	-0.54

Surrogate Model

1. Generate random population
2. Assign a *fitness* to members of the population
3. Train a *surrogate model*
4. Choose the best ones and recombine them to produce *too many offspring*
5. Mutate the offspring
6. Use surrogate to filter out promising offspring
7. Repeat 1-5 until we're done

...speed up of around 20-30%

Mining a surrogate model

Markov network based surrogate

0.017	0.017	0.016	0.016	0.015	0.015	0.015	0.015	0.016	0.015	0.015	0.015	0.016	0.016	0.016
0.016	0.016	0.016	0.016	0.016	0.016	0.016	0.016	0.016	0.015	0.015	0.016	0.015	0.016	0.016
0.017	0.017	0.016	0.016	0.015	0.016	0.016	0.016	0.016	0.016	0.015	0.016	0.016	0.016	0.016
0.017	0.016	0.017	0.017	0.016	0.016	0.015	0.015	0.016	0.015	0.016	0.017	0.016	0.017	0.017
0.017	0.017	0.017	0.016	0.016	0.016	0.016	0.016	0.015	0.016	0.016	0.016	0.017	0.017	0.017
0.017	0.018	0.018	0.017	0.018	0.017	0.017	0.016	0.016	0.017	0.016	0.017	0.016	0.017	0.016
0.018	0.017	0.018	0.018	0.018	0.017	0.017	0.017	0.018	0.017	0.017	0.017	0.016	0.017	0.017
0.017	0.018	0.017	0.018	0.018	0.018	0.018	0.019	0.018	0.019	0.017	0.018	0.018	0.017	0.018

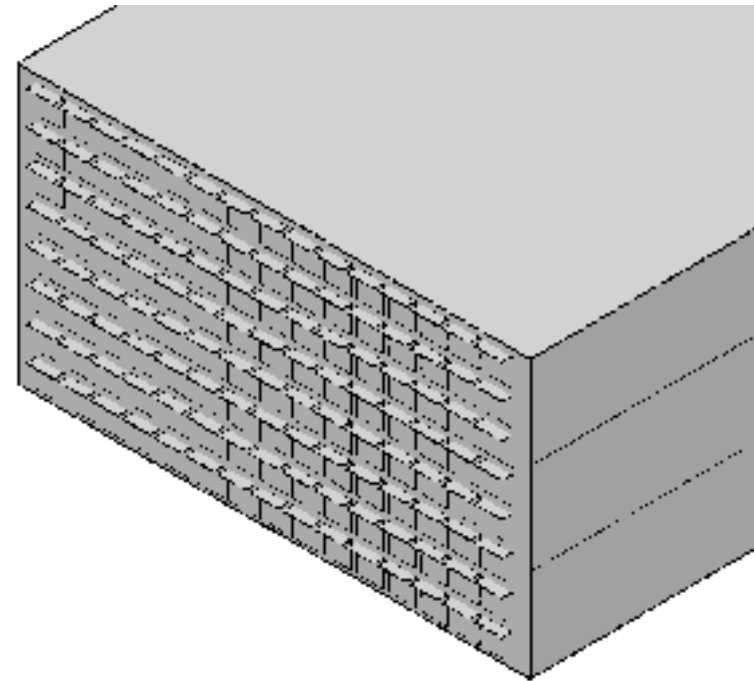



Large scale

- Jump to 69?

Summary

- Optimisation problems everywhere
- Aim to give insight as well as answers
- Where next?
 - Trying to formalise the "value added part"
 - Obvious crossover with existing GA theory, landscapes, grey box optimisation etc...
 - Can we formulate any "search" or "exploration" problem as an optimisation problem and get the same insight?

Surrogate Model

- Limited work done with mixture of continuous and discrete variables, and with constraints
- Approach to constraints same as for FI
 - i.e. predict value then do cut-off
- Using a radial basis function network (RBFN)
- Initially tried a single network
 - Had to retrain whole network if part of it poor
 - Now one network per objective or constraint

RBFN

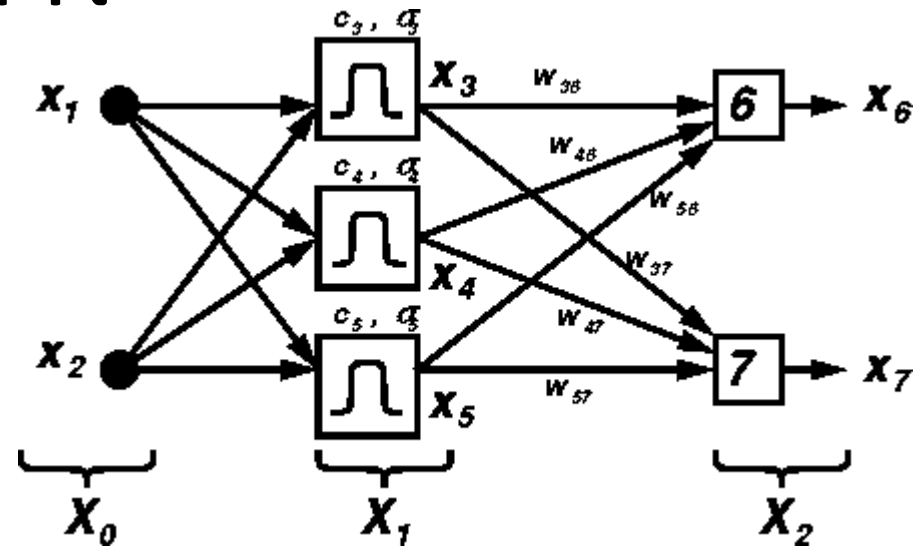

- Feed-forward network
- Input layer: problem vars
- Hidden layer:
 - radial basis functions
 - output similarity to centre
- Output layer:
 - linear weighted sum per objective / constraint
- Distances
 - Euclidian (cont), Manhattan (int), Hamming (bits)

Surrogate Model

1. Random init of population
2. Selection of parents
3. Generate **too many** offspring from parents
 - 3a. Use surrogate to filter out promising offspring
4. Evaluate **filtered** offspring
5. Combine offspring + parents into Q
6. Non-dom sort Q
7. Replace population with top half of Q
8. If termination criteria not met, back to 2

NSGA II with surrogate

Example 3 : Risk of mould growth

- **Variables:** heating, ventilation, aircon system setup and operation
- **Objectives:** Energy, Mould Risk (related to long, warm, damp periods)
- Hospital ward, Kuala Lumpur

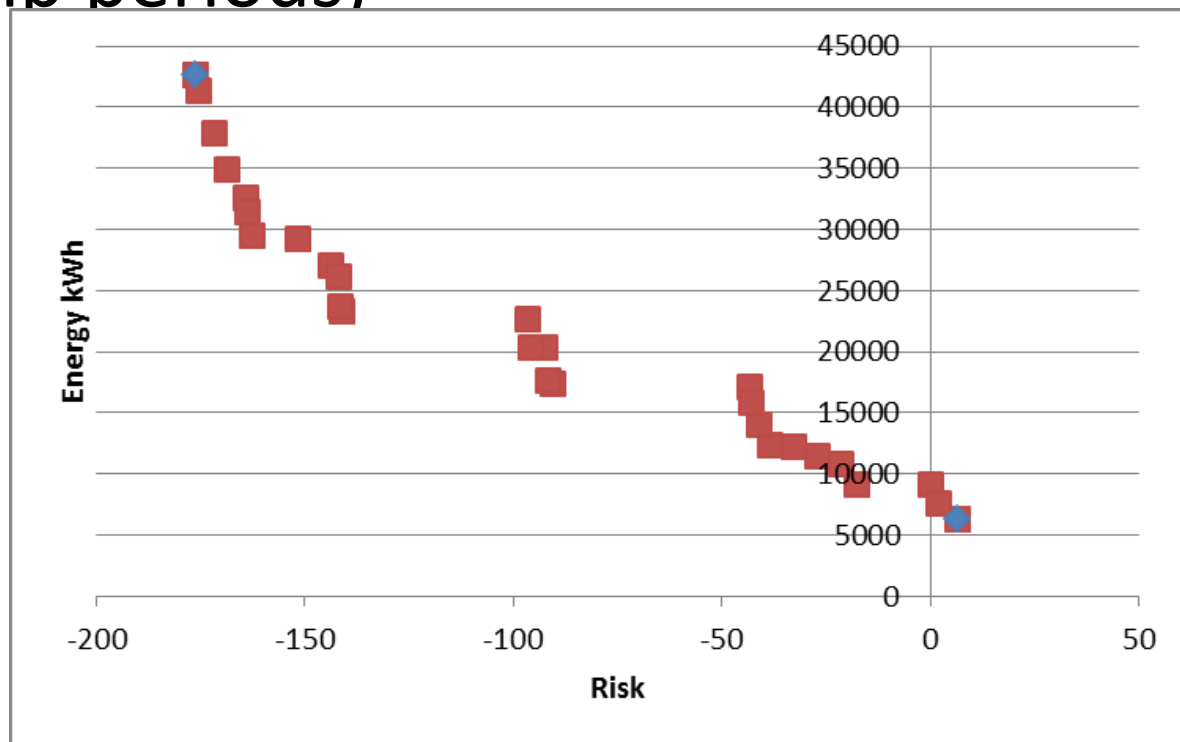

SOFTWARE

AIRFRANCE KLM



2004



87.4

million passengers carried in 2014



316

destinations in 115 countries



546

aircraft in operation at December 31, 2014



Number of passengers carried by the European airlines in 2014

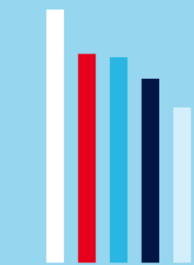

- Lufthansa Group 106 million
- Air France-KLM 87.4 million
- Ryanair 86.4 million
- IAG 77.3 million
- Easyjet 65 million

(source : company communication)

3.3
billion passengers carried in 2014

↓
7.3
billion in 2034
(source : IATA)



4%
Airline traffic is expected to see 4% annual growth over the next 15 years
(source : Boeing)

Global airline ranking



Conversion rate at 24/04/2015

5th

The Air France-KLM Group ranks number five in terms of revenues
(source : company communication)

Air France-KLM is the number one in terms of intercontinental traffic on departure from Europe

Discover the Air France-KLM world



- Destinations operated in 2015 under their proprietary brands by Air France, KLM Royal Dutch Airlines, Transavia and HOP!
- Air France-KLM hubs
- ⊗ New Air France destinations
- ⊗ New KLM Royal Dutch Airlines destinations
- ⊗ New Transavia destinations

Software

- OPiuM – Java based simulator, developed in-house at KLM
- Built on DSOL library, developed at TU Delft

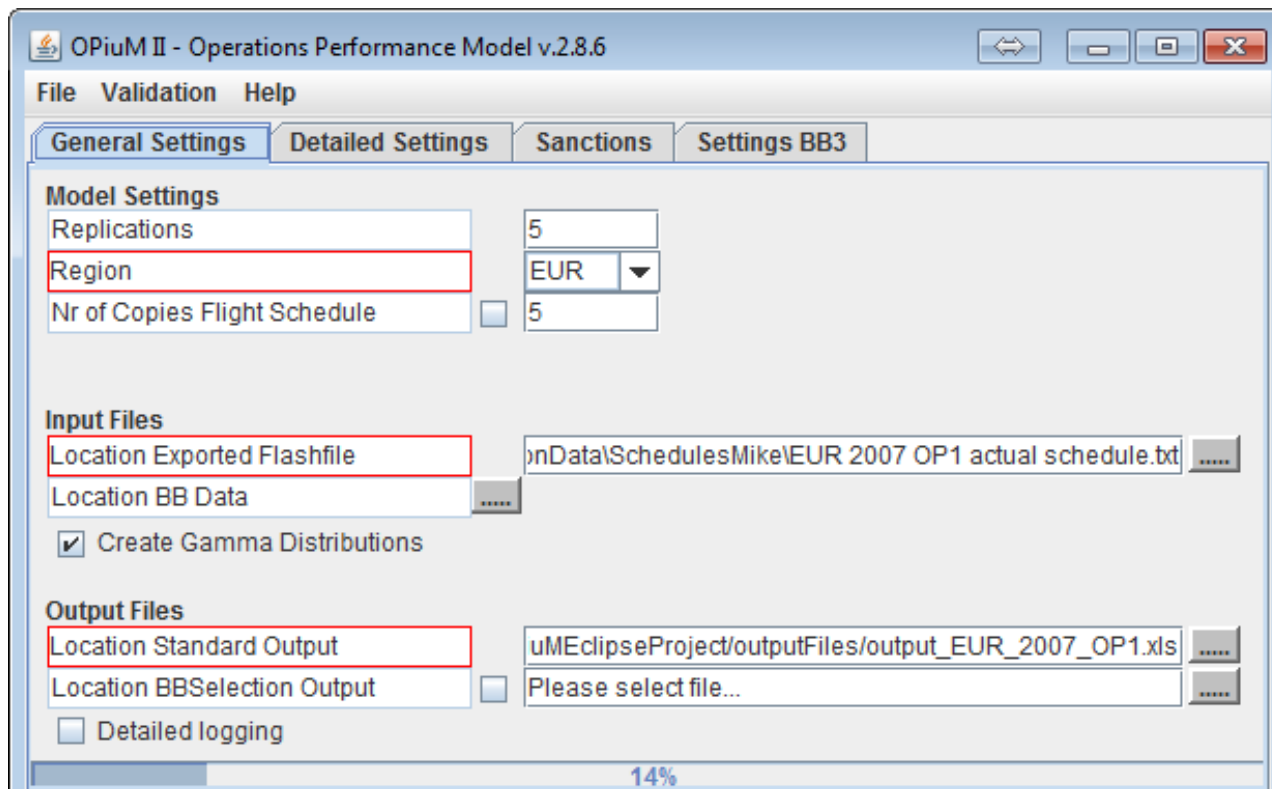

Software

- Simulates aircraft movements given a schedule, estimates possible delays
- One flight schedule:
 - E.g. Europe, 3 months, ~17k flights
- All KLM flight schedules pass through Opium (soon to include Air France too)

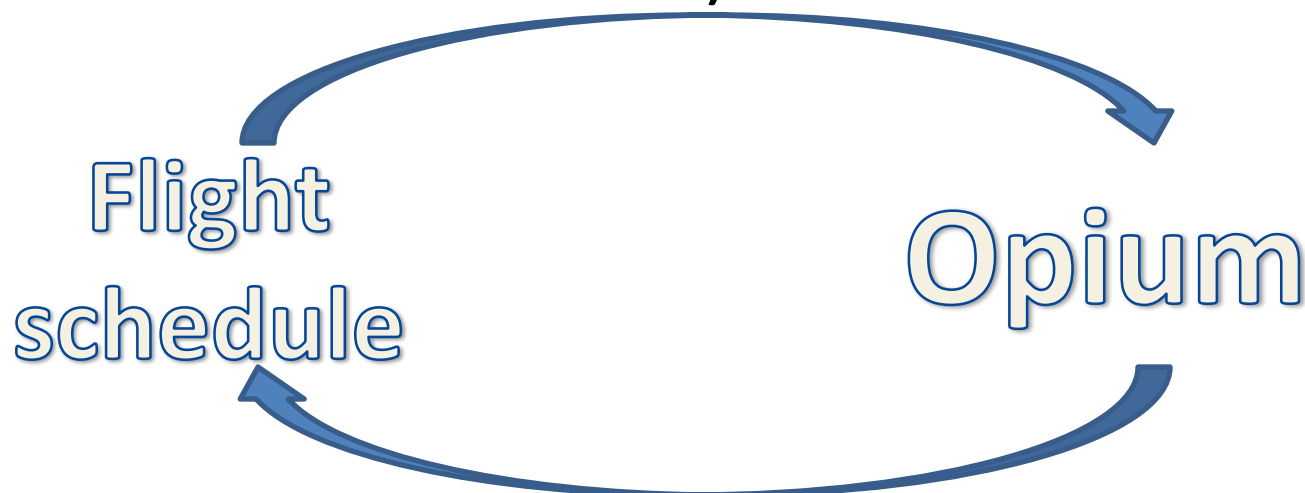

Software

output_EUR_2007_OP2.xls [Compatibility Mode] - Microsoft Excel

File Home Insert Page Layout Formulas Data Review View WWT PDF Architect

Clipboard Font Alignment Number Styles Cells Editing

H17 fx

1 Total KLM 16Nov3010//29Sep2014//29Sep2014

2

3

4 TOTAL PERIOD

5 file:C:\sb\svn\klmopium\OPIuMEclipseProject\OPIuMValidationData\SchedulesMike\EUR 2007 OP2 actual schedule.txt

	AMS						ex-AMS		AMS-OUT			OUT-AMS			in-AMS		AMS					
AcType	AcAv	Ground	ADC	D0	D5	D15	Flight*	Block	A0	A15	ADO	AcAv	Ground	ADC	D0	D5	D15	Flight	Block	A0	A15	ADO
73H	91	62	57	42	64	87	64	75	59	90	61	86	71	69	56	74	92	68	79	72	94	73
73J	86	61	51	37	57	81	65	76	57	83	60	85	62	59	54	69	90	72	76	69	92	71
73W	85	76	67	53	72	89	65	74	66	92	69	83	81	77	65	80	93	65	75	73	93	75
Totals	88	68	61	46	67	87	65	75	62	90	64	84	75	72	60	76	92	67	77	72	94	74

12

13

14 *based on non-rounded times

15

16

17

18

19

20

21

22

23

24

25

26

27

28

29

Output Measures Distributions FltDetails BBselection Run Settings Missing BB

Ready 100%

What to improve?

- Opium software is part of a loop of improving and testing schedules
- so, **faster**, and **at least the same accuracy**

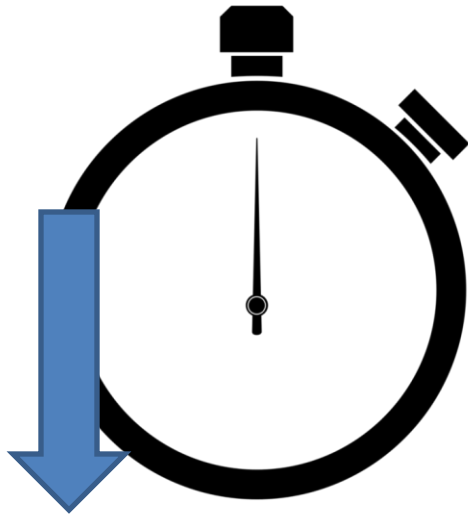

Parameter tuning

- We were provided with real-world schedules and results covering 2007-2010
- Starting point: Opium has 14 external parameters
 - These have been manually tuned over about 10 years, and are now mostly "don't touch"
 - Tune these to improve simulation accuracy (fit to historical data) and simulation run time

Wrapper

- Needed for any kind of automated improvement

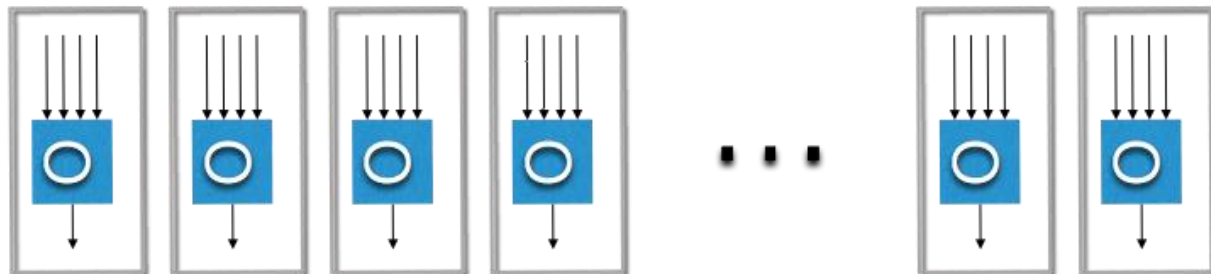
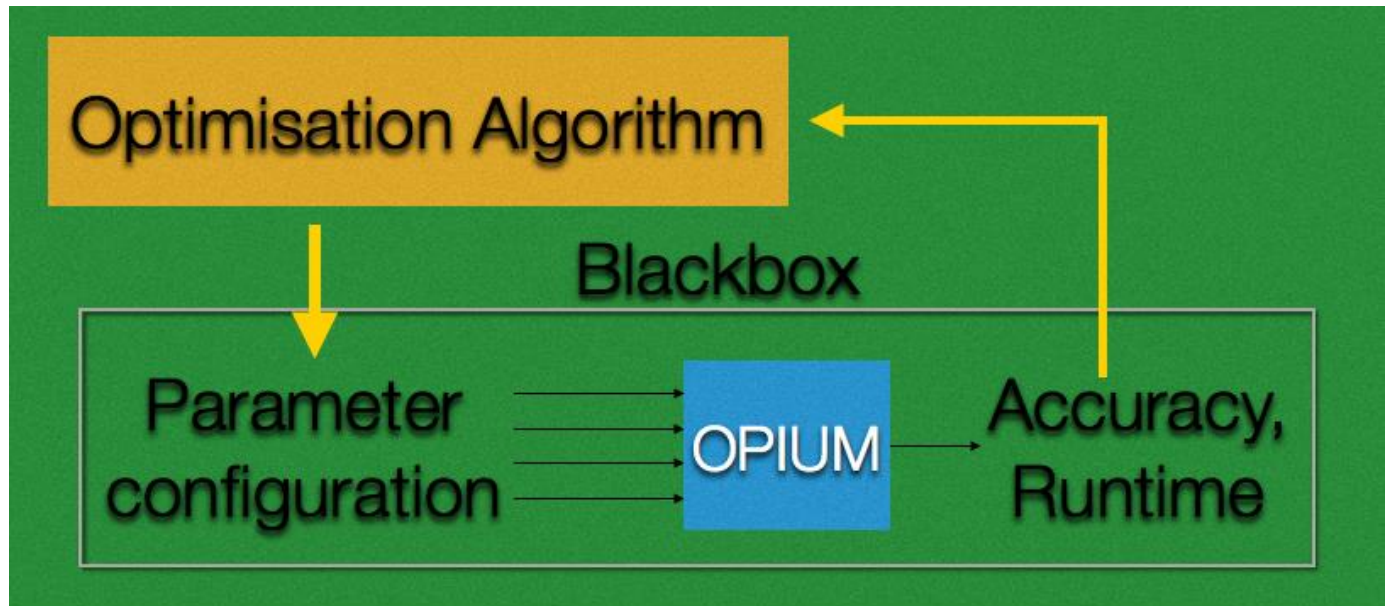

A systematic approach

1. Statistical analysis of the parameters
2. Single objective tuning & model based analysis
3. Seeded multi-objective optimisation

Results:

high-performing configurations, with explanation

Stage 1: statistical analysis

1. Statistical Screening

- Design of experiments / fractional factorial
- Uses lower and upper bounds for each parameter
- Screens out insensitive parameters

2. Exploring the sensitive parameters

- Fine-grained exploration of each parameter
- Exhaustive: accuracy
- Response surface: time

Statistical Screening (Accuracy)

Parameter	LB	UB	P-value
Max Maintenance Reduction	0	0.2	0.177
Ground Factor Out	1	1.3	0.311
Slack Selection BB3	0	50	0.505
Max Legs Swap	2	6	0.404
HSF threshold Out	0	5	0.794
HSF threshold In	0	15	0.789
Max Legs Cancel	1	7	0.018
HSF threshold	0	15	0.625
Cancel Measure On	0	1	0.006
Break Maintenance Measure On	0	1	0.980
Create Gamma	0	1	0
Rounding off method	Regular	None	0.514
Swap Measure On	0	1	0
HSF Measure On	0	1	0.714

Optimal values: Accuracy

- Exhaustive search
 - Search space of 112

Parameter	LB	UB
Max Legs Cancel	1	14
HSF threshold	False	True
Create Gamma	False	True
Swap Measure On	False	True

- Matches default params acc=271.628)
- Importance, high to low:
 - Swap Measure On
 - Create Gamma
 - Cancel Measure On (negligible?)
 - Max Legs Cancel (negligible?)

MLC	CMO	CG	SMO	MSE
1	1	1	1	271.6
2	1	1	1	271.6
3	1	1	1	271.6
4	1	1	1	271.6
5	1	1	1	271.6
6	1	1	1	271.6
7	1	1	1	271.6
8	1	1	1	271.6
9	1	1	1	271.6
10	1	1	1	271.6
11	1	1	1	271.6
12	1	1	1	271.6
13	1	1	1	271.6
14	1	1	1	271.6
1...14	0	1	1	271.6
2...14	1	0	1	292.7
1	1	0	1	306.9
1...14	0	0	1	306.9
2...14	1	1	0	366.2
2...14	1	0	0	453.3
1	1	1	0	564.0
1...14	0	1	0	564.0
1	1	0	0	646.9
1...14	0	0	0	646.9

Time

- Same process for time, but second stage was a response surface experiment (6 params, 520 solutions)
- Optimal config:
 - Run time 476.5s (default was 1406.7)
 - Accuracy (MSE) 426.988 (default was 271.628)
- So some potential for improvement

Stage 2: single-objective tuning

- Automatic Hyper-parameter Optimization
 - Optimization with **irace**
 - Optimization with **SMAC**
 - "Optimal" configurations found
 - Best was acc 241.268 vs 271.628
 - Probably because of interactions
 - Functional ANOVA (fANOVA) main/pairwise interactions

fANOVA main/pairwise effects

Sum of fractions for main effects 68.91%	
Sum of fractions for pairwise interaction effects 16.30%	
54.25% due to main effect	Swap_Measure_On
4.05% due to interaction	Swap_Measure_On x Cancel_Measure_On
4.02% due to main effect	Cancel_Measure_On
3.57% due to main effect	CreateGamma
3.55% due to main effect	Rounding_off_method
2.16% due to interaction	Swap_Measure_On x Slack_Selection_BB3
2.13% due to main effect	Slack_Selection_BB3
1.35% due to interaction	Slack_Selection_BB3 x Cancel_Measure_On
1.28% due to interaction	Swap_Measure_On x Rounding_off_method
0.84% due to interaction	Swap_Measure_On x CreateGamma
0.82% due to interaction	Slack_Selection_BB3 x CreateGamma
0.75% due to interaction	CreateGamma x Cancel_Measure_On
0.63% due to main effect	Ground_Factor_Out
0.55% due to interaction	Slack_Selection_BB3 x Rounding_off_method
0.48% due to interaction	Slack_Selection_BB3 x HSF_threshold
0.44% due to interaction	Slack_Selection_BB3 x HSF_threshold_In
0.36% due to interaction	Rounding_off_method x CreateGamma
0.33% due to main effect	HSF_threshold
0.33% due to main effect	HSF_threshold_In
0.33% due to interaction	Swap_Measure_On x HSF_threshold_In
0.31% due to interaction	Swap_Measure_On x Ground_Factor_Out
0.31% due to interaction	Swap_Measure_On x HSF_threshold
0.25% due to interaction	Rounding_off_method x Cancel_Measure_On
0.24% due to interaction	HSF_threshold_In x Cancel_Measure_On
0.21% due to interaction	HSF_threshold x Cancel_Measure_On
0.15% due to interaction	Rounding_off_method x HSF_threshold_In
0.15% due to interaction	HSF_threshold_In x CreateGamma
0.13% due to interaction	Rounding_off_method x Ground_Factor_Out
0.12% due to interaction	HSF_threshold x CreateGamma
0.10% due to interaction	Slack_Selection_BB3 x Ground_Factor_Out

Integer marginal distributions

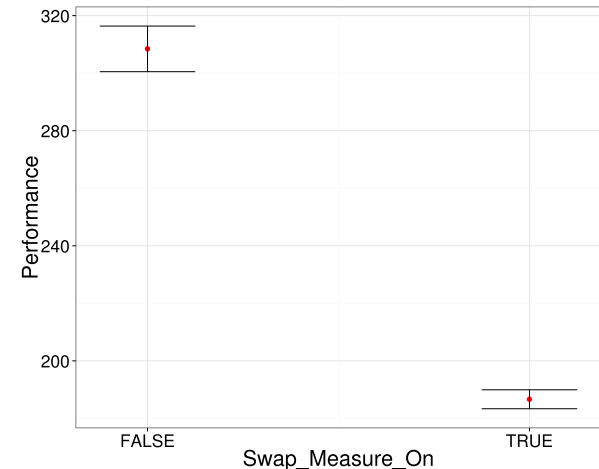
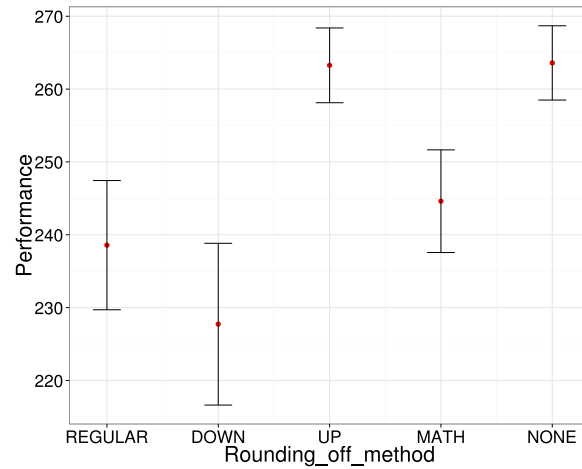
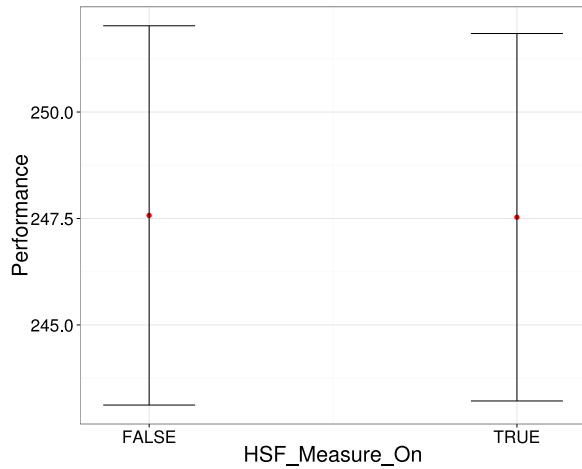
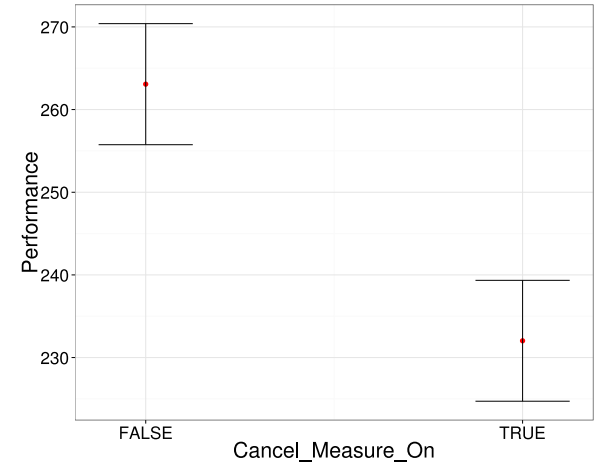
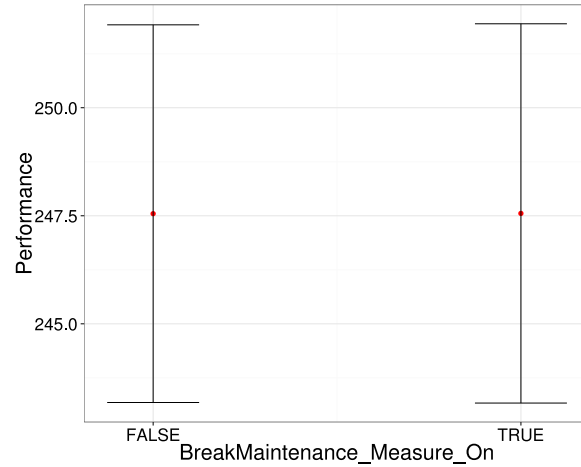
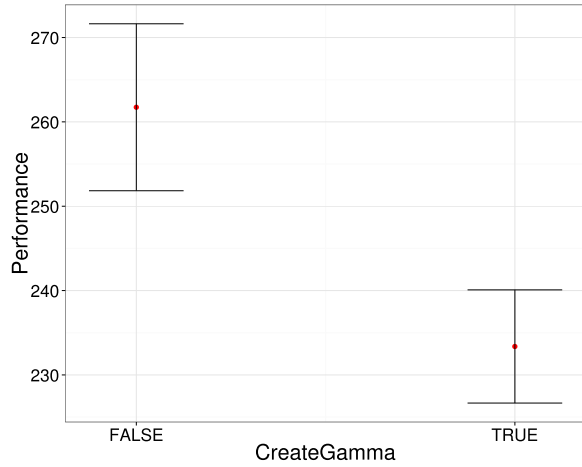

Continuous marginal distributions

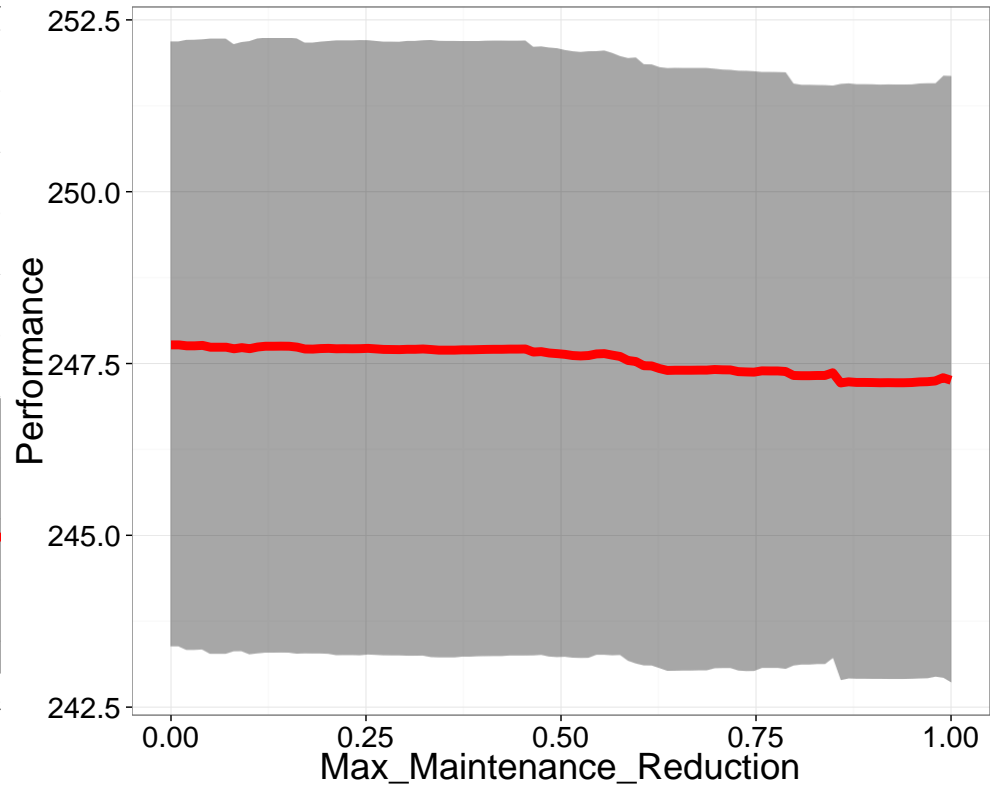
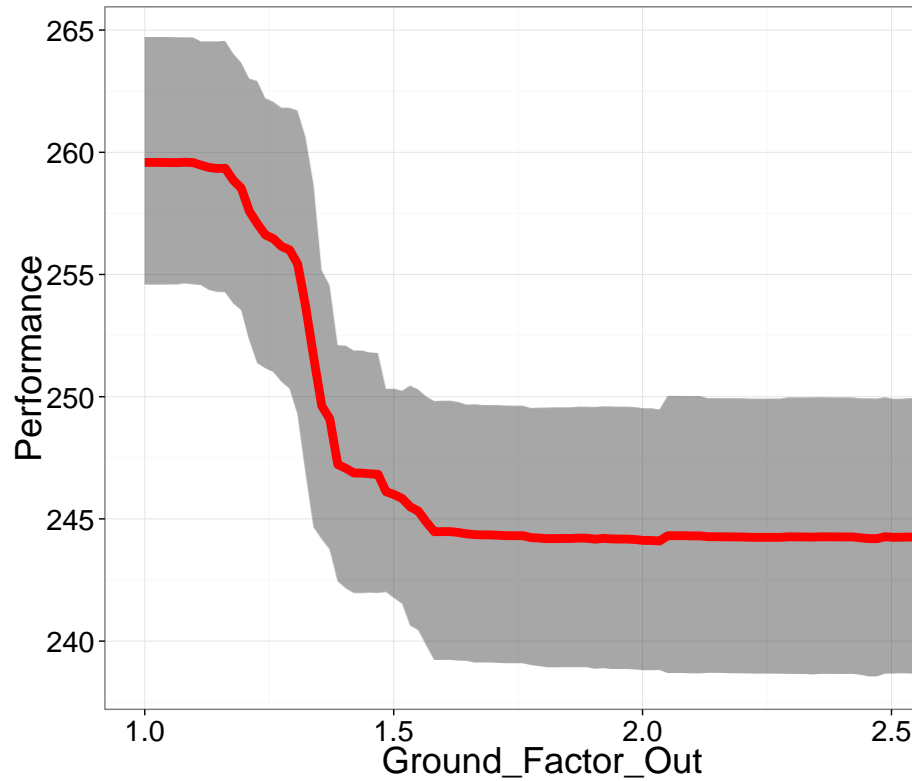

Stage 3: Multi-objective Optimisation

- Improvement in both objectives!
- Highlighted params correspond with statistical analysis

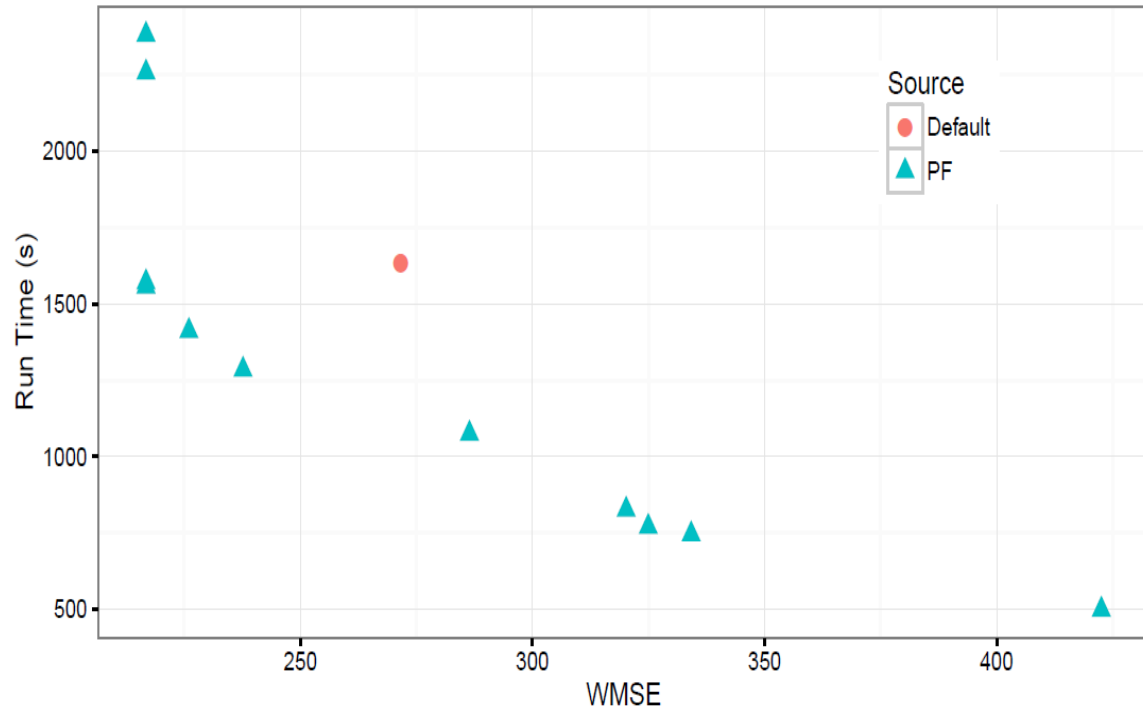

MMR	GFO	SSBB3	MLS	HSFTO	HSFTI	MLC	HSFT	CMO	BMMO	CG	ROM	SMO	HSFMO	MSE	RunTime
0.25	1.8	90	9	3	49	9	13	1	0	1	1	1	0	216.748	2382.6
0.25	1.8	90	8	3	48	5	0	1	0	1	1	1	0	216.748	2258.4
0.2	1.8	90	8	12	51	10	2	1	0	1	1	1	0	216.748	1570.9
0.2	1.8	90	8	3	49	5	2	1	0	1	1	1	0	216.748	1557.2
0.25	1.8	50	9	28	51	2	0	1	0	1	1	1	0	225.988	1411.4
0.35	1.8	40	3	9	50	5	1	1	0	1	0	1	0	237.648	1284.5
0.25	1.55	60	12	25	47	9	8	1	1	0	1	1	0	286.428	1075.0
0.25	1.6	100	7	2	48	10	2	1	0	1	1	0	0	320.188	825.8
0.2	1.6	100	4	5	12	10	15	1	0	1	0	0	0	324.948	769.4
0.5	1.3	100	12	6	40	10	14	1	1	1	1	0	1	334.188	745.0
0.25	1.7	10	12	24	46	10	7	1	0	0	1	0	0	422.548	498.0

Summary

- Optimisation problems everywhere
- Aim to give insight as well as answers
- Where next?
 - Trying to formalise the "value added part"
 - Obvious crossover with existing GA theory, landscapes, grey box optimisation etc...
 - Can we formulate any "search" or "exploration" problem as an optimisation problem and get the same insight?